

Abstract

We introduce C^r -open sets, $r = 1, 2, \dots, \infty$, of symplectic diffeomorphisms and Hamiltonian systems exhibiting *large* robustly transitive sets. As a consequence of the constructions we show that, arbitrarily C^∞ -close to certain (nearly) integrable Hamiltonian systems with more than two degrees of freedom, there exist systems with unbounded robustly transitive sets.

Acknowledgements

I would like to thank my advisor Enrique Pujals for many insightful discussions. I am indebted to him and Jacob Palis for their advice, support and enormous encouragement. I am truly grateful to Marcelo Viana for his constant support. I am also grateful to Lorenzo Díaz, Mike Shub and Patrice Le Calvez for useful conversations and comments.

I also wish to acknowledge the hospitality of IHP-Paris during the workshop “Time at work”, May-June 2005. I wish to stress the remarkable research atmosphere at IMPA and to acknowledge financial support of IMPA-CNPq.

Many thanks to my good friends at IMPA.

Finally, I have no words to express my gratitude to my family.

تقدیم به پدر و مادرم

To my parents

Contents

Abstract	iii
Acknowledgements	iv
1 Introduction and main results	1
1.1 Preliminaries	3
1.2 Main results	6
2 Iterated function system	11
2.1 Contracting and expanding maps	12
2.2 Recurrent diffeomorphisms	15
2.3 Skew products and IFS	22
3 Symplectic blender	27
3.1 <i>cs</i> -blender with higher dimensional unstable central bundle	29
3.2 Double-blender: affine model	32
3.3 Symplectic blender: affine model	33
3.4 Symplectic blender: general construction	34
4 Proof of Theorem A	36
4.1 The perturbations	36
4.2 Constructing symplectic blender	38
4.3 Almost minimality of stable and unstable foliations	42

4.4	Robustness of the almost minimality of foliations	44
4.5	Transitivity and topological mixing	46
5	Instabilities in nearly integrable systems	49
5.1	Instability versus recurrency	49
5.2	Proofs of Theorem C and Corollary D	51
6	Some remarks and open problems	54

Chapter 1

Introduction and main results

The theory of Kolmogorov, Arnold and Moser, (KAM) gives a precise description of the dynamics of a set of large measure of orbits for any small perturbation of a non-degenerate integrable Hamiltonian system. These orbits lie on the invariant KAM tori for which the dynamics are equivalent to irrational (Diophantine) rotations. This theory applies for the autonomous Hamiltonians, time-periodic Hamiltonians and also symplectic diffeomorphisms. A basic and natural question is what happens for other orbits. What is the possible behavior of most orbits (in the topological sense) for generic systems?

In the case of autonomous systems in two degrees of freedom or time-periodic systems in one degree of freedom (i.e., 1.5 degrees of freedom), KAM Theorem proves the stability of *all* orbits, in the sense that the actions do not vary much along the orbits. Since each KAM torus has codimension one in the phase space, its complement is disconnected and contains two connected invariant components. Thus, any orbit remains between two nearby invariant tori. This, of course, is not the case if the degree of freedom is larger than two, where the KAM tori are of codimensions at least two. A natural question arises: Do generic perturbations of integrable systems in higher dimensions exhibit instabilities?

The problem of instabilities for high dimensional nearly integrable Hamiltonian systems (i.e. small perturbations of integrable systems) has been considered one of the most important problems in Hamiltonian dynamics. The first example of instability is due to Arnold [A2], who constructed a family of small perturbations of a non-degenerate integrable Hamiltonian system that exhibits instability in the sense that there are orbits for which the variation of action is large. This kind of topological instability is sometimes called the *Arnold diffusion*. In fact, he had conjectured [A1, pp. 176] that the answer of the above question should be positive. While there is a large number of works and announcements towards this conjecture, specially in the recent years (see e.g. [CY], [D], [DLS], [KMV], [Ma], [X], and references there), little is known about “most of the orbits” in the complement of invariant or periodic Diophantine tori. Although it is very difficult to prove the existence of “some” instable orbits in general, it is the simplest expected non-trivial behavior in the complement of invariant tori. For instance, one may ask about transitivity or topological mixing.

On the other hand, in non-conservative dynamics, there are several important recent contributions about robust transitivity. Recall that a diffeomorphism of a manifold M is transitive if it has a dense orbit in the whole manifold. Such a diffeomorphism is called C^r -robustly transitive if it belongs to the C^r -interior of the set of transitive diffeomorphisms. It has been known since the 1960's, that any hyperbolic basic set is C^1 -robustly transitive. The first examples of non-hyperbolic C^1 -robustly transitive sets are due to M. Shub [Sh] and R. Mañé [Mñ]. For a long time their examples remained unique. Then, L. Díaz (who was mainly interested in the dynamical consequences of hetero-dimensional cycles), jointly with C. Bonatti, discovered [BD] a semi-local source for transitivity, which is C^1 robust. They called it *blender*. Using this tool, one may construct examples of robustly transitive sets and diffeomorphisms. Conversely, Bonatti, Díaz, Pujals, Ures, [DPU], [BDP] have shown that any C^1 robustly transitive set admits an invariant dominated splitting on its tangent bundle,

and a weak form of hyperbolicity holds. This result has been extended independently by Horita, Tahzibi [HT] and by Saghin [Sa] to the symplectic case, where the robust transitivity holds only in the space of symplectic diffeomorphisms. Another important result in this direction is due to Arnaud, Bonatti and Crovisier [BC], [ABC]. They show that generically in the C^1 topology any symplectic diffeomorphism on a compact manifold is transitive. They also prove that on non-compact manifolds, generic orbits of generic diffeomorphisms are not bounded. It is important to note that the C^1 topology is essential in all these results, because of the use of several basic perturbation lemmas (connecting lemmas, Franks Lemma, etc.) known only in the C^1 topology. For the recent surveys on this topic and on a related theory about stably ergodic diffeomorphisms on compact manifolds, developed in the last decade by C. Pugh, M. Shub, and many others, see [BDV, chapters 7,8], [PS], [PSh].

A goal of this paper is to study the dynamics in the complement of invariant KAM tori with a focus on the non-local robust phenomena. We develop the methods of robust transitivity into the context of symplectic and Hamiltonian systems. And then we apply them for the nearly integrable symplectic and Hamiltonian systems with more than two degrees of freedom. We introduce such Hamiltonians or symplectic diffeomorphisms exhibiting *unbounded or large* robustly transitive sets. Then, the instability (or the so-called Arnold diffusion) is obtained as a consequence of the existence of large or unbounded robustly transitive sets.

1.1 Preliminaries

Let us now introduce some definitions before stating the main results. Let $f : M \rightarrow M$ be a diffeomorphism of a compact manifold M . An f -invariant subset Λ is *partially hyperbolic* if its tangent bundle $T_\Lambda M$ splits as a Whitney sum of Tf -invariant

subbundles:

$$T_\Lambda M = E^u \oplus E^c \oplus E^s,$$

and there exist a Riemannian metric on M and constants $0 < \lambda < 1$ and $\mu > 1$ such that for every $p \in \Lambda$,

$$0 < \| T_p f|_{E^s} \| < \lambda < m(T_p f|_{E^c}) \leq \| T_p f|_{E^c} \| < \mu < m(T_p f|_{E^u})$$

The co-norm $m(A)$ of a linear operator A between Banach spaces is defined by $m(A) := \inf\{\| A(v) \| : \| v \| = 1\}$. The bundles E^u , E^c and E^s are referred to as the unstable, center and stable bundles of f , respectively.

An example of a partially hyperbolic set is a *hyperbolic set*, for which $E^c = 0$.

Let f and g be two diffeomorphisms on manifolds M and N , respectively. Suppose that $\Lambda \subset M$ is an invariant hyperbolic set for f . We say g is dominated by $f|_\Lambda$ if $\Lambda \times N$ is a partially hyperbolic set for $f \times g$, with $E^c = TN$.

In a similar way one may define partially hyperbolic sets in a non-compact boundaryless manifold.

Let p be a hyperbolic periodic point of g , we say that p is δ -weak hyperbolic if

$$1 - \delta < m(T_p g) < \| T_p g|_{E_p^s} \| < 1 < m(T_p g|_{E_p^u}) < \| T_p g \| < 1 + \delta.$$

Let X be a metric space, and $F : X \rightarrow X$. A set $Y \subset X$ is *transitive* for F if for any U_1, U_2 open in X , such that $U_i \cap Y \neq \emptyset$, there is some n with $F^n(U_1) \cap U_2 \neq \emptyset$. If in addition, for any open sets $U_1, U_2 \subset Y$ (in the restricted topology), there is some n with $F^n(U_1) \cap U_2 \neq \emptyset$, then we say Y is *strictly transitive*. A stronger property is *topological mixing*, where $F^n(U_1) \cap U_2 \neq \emptyset$ holds for *any* sufficiently large n .

Let D^r be a subspace of $\text{Diff}^r(M)$ with the C^r topology.

An invariant set $X \subset M$ of f has *continuation* in D^r , if there exist an open

neighborhood \mathcal{U} of f in D^r , and a continuous map $\Phi : \mathcal{U} \rightarrow \mathcal{P}(M)$ such that, $\Phi(f) = X$, and for any $g \in \mathcal{U}$, the set $\Phi(g) \subset M$ is homeomorphic to X and invariant for g . Then we call $\Phi(g)$ is the *continuation* of X for g . Here, $\mathcal{P}(M)$ is the space of all subsets of M with the Hausdorff topology.

A compact set $Y \subset M$ is *D^r -robustly transitive* for $f \in D^r$, if for any $g \in D^r$ sufficiently close to f , the continuation of Y does exist and it is transitive for g . More generally if M is not compact, a non-relatively compact set $Y \subset M$ is *D^r -robustly transitive* if it is the union of an increasing sequence of D^r -robustly compact transitive sets. In the same way one may define robustly (strictly) topological mixing.

A point x is *non-wandering* for a diffeomorphism f if for any neighborhood U of x there is $n \in \mathbb{N}$ such that $f^n(U) \cap U \neq \emptyset$. By $\Omega(f)$ we denote the set of all non-wandering point of f .

A point x is *recurrent* for a homeomorphism f if $\liminf_{n \rightarrow \infty} \text{dist}(x, f^n(x)) = 0$. A homeomorphism or diffeomorphism is said *recurrent* if almost all points are recurrent.

Now, let us recall some basic facts and definitions of symplectic topology. A symplectic manifold is a C^∞ smooth boundaryless manifold M together with a closed non-degenerate differential 2-form ω . We denote it by (M, ω) but sometimes we just write M . Examples of symplectic manifolds are orientable surfaces, even dimensional tori and cylinders, and the cotangent bundle T^*N of an arbitrary smooth manifold. A C^1 diffeomorphism f is *symplectic* if f preserve ω ; i.e. $f_*\omega = \omega$. We denote by $\text{Diff}_\omega^r(M)$ the space of C^r symplectic diffeomorphisms of M with the C^r topology, $1 \leq r \leq \infty$. If the symplectic form ω is exact, that is $\omega = d\alpha$ for some 1-form α , and $f_*\alpha - \alpha = dS$ for some smooth function $S : M \rightarrow \mathbb{R}$, then we say that f is an exact symplectic diffeomorphism.

The following theorem is a variant of the results [HPS] on persistence of normally hyperbolic laminations extended to the non-compact embedded.

Theorem 1.1. *Let M and N be two boundaryless manifolds (not necessarily com-*

compact). Let $f_1 \in \text{Diff}^1(M)$ with an invariant hyperbolic compact set Λ . Let $f_2 \in \text{Diff}^1(N)$ such that is dominated by $f_1|_\Lambda$. Then the invariant set $\Lambda \times N$ has a unique continuation for $f_1 \times f_2$ in $\text{Diff}^1(M \times N)$

1.2 Main results

Our main result concerning symplectic diffeomorphisms is the following.

Theorem A. *Let M and N be two symplectic manifolds (not necessarily compact), and $1 \leq r \leq \infty$. Let $f_1 \in \text{Diff}_\omega^r(M)$ such that there exists an open set $U \subset M$ whose maximal invariant set Λ is a hyperbolic transitive compact set. Let $f_2 \in \text{Diff}_\omega^r(N)$ such that:*

- a) f_2 is dominated by $f_1|_\Lambda$, and
 f_2 has a δ -weak hyperbolic periodic point for some positive $\delta = \delta(f_1, f_2)$.
- b) For any \tilde{f}_2 sufficiently C^r close to f_2 , $\Omega(\tilde{f}_2) = N$.

Then there is a C^r -arc $\{F_\mu\}_{\mu \in [0,1]}$ of C^r symplectic diffeomorphisms on $M \times N$, such that $F_0 = f_1 \times f_2$, and for all $\mu \in (0, 1]$, there exist a set $\Gamma_\mu \subset \Lambda \times N$ verifying

1. Γ_μ is robustly strictly topologically mixing in $\text{Diff}_\omega^r(M \times N)$ for F_μ ,
2. for any $x \in \Lambda$, the set $(\{x\} \times N) \setminus \Gamma_\mu$ is closed and has Lebesgue zero measure.
 In particular, $\overline{\Gamma_\mu} = \Lambda \times N$

Theorem A, roughly speaking, says that if the product of a hyperbolic basic set Λ by any non-wandering dynamics on N is partially hyperbolic then we can perturb it such that (the continuation of) $\Lambda \times N$ become a robustly topological mixing set.

Remark that the non-wandering hypothesis (b) is obviously satisfied if the manifold N is compact or has a finite volume.

Corollary B. *Let $f_1 \in \text{Diff}_\omega^r(M)$ with a quasi-elliptic periodic point, and $f_2 \in \text{Diff}_\omega^r(N)$ be an integrable diffeomorphism, where M and N are compact symplectic manifolds, and $r \in \mathbb{N} \cup \{\infty\}$. Then $f_1 \times f_2$ is C^∞ approximated by $F \in \text{Diff}_\omega^r(M \times N)$ such that F has a robustly topological mixing set whose projection on N is equal to N .*

Corollary B is also related to an interesting example of Shub and Wilkinson [SW]. They proved that the product of “Anosov \times Standard map” on \mathbb{T}^4 is C^∞ approximated by (symplectic) stably ergodic systems. The ergodicity implies transitivity, but not topologically mixing. In the proof they use the central tool in the theory of stable ergodicity, namely, the *accessibility*. Two things seem essential in their proof. The first one is global (partial) hyperbolicity and the second one is compactness. See also Remark 6.1. On the other hand, their example can not occur near to integrable systems. In fact, there is no ergodic nearly integrable system, because the union of invariant KAM tori has positive Lebesgue measure. Corollary B may also provides a local and topological version of this example.

Let (M, ω) be a symplectic manifold and $H : \mathbb{R} \times M \rightarrow \mathbb{R}$ a C^r function, called the (time dependent) Hamiltonian. For any $t \in \mathbb{R}$, the vector field X_{H_t} determined by the condition

$$\omega(X_{H_t}, Y) = dH_t(Y) \text{ or equivalently } i_{X_{H_t}}\omega = dH_t$$

is called the *Hamiltonian vector field* associated with $H_t := H(t, \cdot)$ or the symplectic gradient of H_t . The Hamiltonian H is called time periodic if $H_t = H_{t+T}$ for some $T > 0$. A diffeomorphism is called *Hamiltonian diffeomorphism* if it is the time-one map of some time periodic Hamiltonian flow.

Remark 1.2. Theorem A can be stated in the context of exact and Hamiltonian diffeomorphisms, and also time-dependent Hamiltonians. The statements are analogues

and it is left to the reader.

Theorem C. *Let M and N be two symplectic manifolds (not necessarily compact), and h_1 and h_2 be two C^r Hamiltonians on M and N , respectively. Let f_1 and f_2 be the time one map of the hamiltonian flow generated by h_1 and h_2 , respectively. Suppose that*

- (i) h_1 is time periodic and f_1 has a transversal homoclinic point,
- (ii) f_2 is dominated by a hyperbolic invariant set of f_1 ,
- (iii) the whole manifold N is the non-wandering set for h_2 .

Then the Hamiltonian h_1+h_2 is approximated in C^∞ topology by time-periodic Hamiltonians H_μ on $M \times N$ exhibiting a topologically mixing partially hyperbolic invariant set $\Xi \times N$. Moreover, for any small perturbation of H_μ , the continuation of this set is well defined, and either it remains topologically mixing or it contains wandering points converging to infinity.

As a matter of fact, all known results about instability (Arnol'd diffusion) of symplectic or Hamiltonian systems concern with nearly integrable systems. There are two reasons for it. First, for nearly integrable systems stability seems *a priori* highly probable, and the invariant KAM tori are the “obstructions for instability”. So, to study the instabilities in general, one considers perturbations of integrable systems as the most crucial examples. Second, KAM theory gives useful dynamical information of the system, and this information is crucial in the classical methods for proving instabilities. One of the advantages of Theorem C is that the initial system $h_1 + h_2$ is not necessarily close to the integrable systems.

When the manifold N is of dimension two, then as we mentioned before, existence of invariant KAM tori provides the stability of all points. In particular, there is no wandering point. The following corollary concerns the class of integrable systems that contains the so-called *a priori* unstable integrable Hamiltonian systems H (cf. [CY], [DLS], [X]).

Corollary D. *Let $H_0(p, q, x, y, t) = h_2(p) + h_1(x, y, t)$ be a time-periodic Hamiltonian, where $t \in \mathbb{T} := \mathbb{R}/\mathbb{Z}$ is the time, $(p, q) \in \mathbb{R} \times \mathbb{T}$, and $(x, y) \in \mathbb{R}^n \times \mathbb{T}^n$. Suppose that $h_2(p) = p^2$, and let h_1 be an arbitrary Hamiltonian with some non-hyperbolic periodic orbit. Then, C^∞ -arbitrarily close to H_0 , there are C^r ($r \geq 5$) open sets of time periodic Hamiltonians exhibiting instability, namely, there exist topologically mixing invariant sets containing arbitrary large regions of the action variable p .*

Let us say a few words on the proofs. The first ingredient is a new tool in symplectic dynamics called *symplectic blender*, a semi-local source of robust transitivity. It is based on the seminal work of Bonatti and Díaz [BD]. The symplectic blender provides *robustness* of the density of stable and unstable manifolds of a hyperbolic periodic point, in any compact region, which implies robustness of transitivity or even topological mixing.

Another main ingredient is that we reduce the problem to a one of the iterated function systems. Indeed, in comparison with the classical methods for instability, here we follow the dynamical consequences of the whole structure of homoclinic intersections of a normally hyperbolic submanifold, instead of only one of such intersections. Any homoclinic intersection introduces a holonomy map (or the outer maps of [DLS]), hence considering the whole structure of homoclinic intersections we will have infinitely many different outer maps, and this allows us to obtain instability, but also transitivity. We found the iterated function system as a natural and nice context to set down this idea. As a model one may consider perturbations of the product of a horseshoe and an integrable twist map and then results on the iterated function system yield minimality of (strong) stable and unstable foliations. Then using the *symplectic blender* one can show that transitivity (or even topological mixing) appears in an action variable and in a robust fashion.

Note specially that we do not use any KAM-type invariant sets in the proof. For instance, *recurrency* has an important role. And therefore, the classical problem,

the large gap problem does not make sense here, although the large gaps between Diophantine tori may appear in a normally hyperbolic manifold N .

This thesis is organized as the following. In Chapter 2 we study transitivity of two different kinds of the iterated function systems (IFS). Namely, the IFSs of expanding maps, and the IFSs of recurrent diffeomorphisms. We use the former ones in Chapter 3, where we introduce the symplectic blenders. In Chapter 4 we prove Theorem A. In Chapter 5 we prove Theorem C and Corollary D. Finally, in Chapter 6 several remarks and open problems related to the main results are discussed.

Chapter 2

Iterated function system

In this chapter we study transitivity of some iterated function system (IFS). In the IFSs, instead of taking iteration by only *one map*, one considers all the possible compositions and iterations of *several maps*. As a consequence, a point x may have an infinite number of orbits. The transitivity of the iterated function systems of expanding maps has a fundamental role in the construction and properties of blenders (see Chapter 3). Also the transitivity of the iterated function system of symplectic maps shall be used in the proof of density of (strong) stable and unstable manifolds (see Chapter 4).

Let g_1, g_2, \dots, g_n be some maps defined on the metric space X . The iterated function system $\mathcal{G}(g_1, g_2, \dots, g_n)$ is the action of the (semi-) group generated by $\{g_1, g_2, \dots, g_n\}$ on X . We use the notion of multi-index $\sigma = (\sigma_1, \dots, \sigma_k) \in \{1, 2, \dots, n\}^k$ for $g_\sigma = g_{\sigma_k} \circ \dots \circ g_{\sigma_1}$. We also denote $|\sigma| := k$.

An orbit of $x \in X$ under the iterated function system $\mathcal{G} = \mathcal{G}(g_1, g_2, \dots, g_n)$ is a sequence $\{g_{\Sigma_k}(x)\}_{k=1}^\infty$ where $\Sigma_k = (\sigma_1, \dots, \sigma_k)$ and $\{\sigma_i\}_{i=1}^\infty \in \{1, 2, \dots, n\}^\mathbb{N}$.

The \mathcal{G} -orbit of x denoted by $\text{Orbit}_{\mathcal{G}}^+(x)$ is the set of points lying on some orbit of $x \in X$ under the IFS \mathcal{G} . The \mathcal{G} -orbit of a subset $U \subset X$ is defined as the union of all its orbits, i.e. $\text{Orbit}_{\mathcal{G}}^+(U) = \cup_{x \in U} \text{Orbit}_{\mathcal{G}}^+(x)$.

Similarly, we denote $\text{Orbit}_{\mathcal{G}}^-(x)$ as the set of points that x lies on (some of) their orbits.

Definition 2.1. The IFS $\mathcal{G}(g_1, g_2, \dots, g_n)$ is said *transitive* if the \mathcal{G} -orbit of any open set is dense. A set U is transitive for \mathcal{G} if the \mathcal{G} -orbit any open subset of U is dense in U . This is equivalent to the existence of some point with dense \mathcal{G} -orbit in U .

Remark 2.2. In similar way one defines IFS of maps $g_i : U_i \subset X \rightarrow X$. In this case, the possible compositions of g_i 's depends to each point. $g_i(U_i)$ is not necessarily a subset of U_j and so $g_j \circ g_i$ is only defined on $U_i \cap g_i^{-1}(U_j)$.

2.1 Contracting and expanding maps

In this section we study the transitivity for the iterated function systems of contracting and expanding maps. The results presented here will be used in the construction of blender in Chapter 3.

A map ϕ on a metric space (X, d) is contracting iff there is a constant $0 < K < 1$ such that $d(\phi(x), \phi(y)) < Kd(x, y)$, for all $x, y \in X$. The *contraction bound* (if exists), is a number $\lambda \in (0, 1)$ for which, ϕ in addition satisfies $\lambda d(x, y) < d(\phi(x), \phi(y))$, for all $x, y \in X$. This constant does not exist for any contracting map. For example, if some points converges super-exponentially fast to the unique fixed point of ϕ , and it can easily be constructed. For generic smooth contracting map ϕ on \mathbb{R}^n , the contraction bound does exist if we consider its restriction on a compact domain U . In this case, the constant is equal to $\inf\{m(Df_z) : z \in U\}$.

Proposition 2.3. *Let $U \subset \mathbb{R}^n$ be an open disk containing 0 and $\phi : U \rightarrow U$ be a contracting map with the contraction bound λ and $\phi(0) = 0$. Then there exists $k \in \mathbb{N}$ such that for any $\varepsilon > 0$ small there exist vectors $c_1, \dots, c_k \in B_\varepsilon(0)$ and a number $\delta > 0$ such that*

$$B_\delta(0) \subset \overline{\text{Orbit}_{\mathcal{G}}^+(0)},$$

where $\mathcal{G} = \mathcal{G}(\phi, \phi + c_1, \dots, \phi + c_k)$. Moreover,

$$\delta \geq \frac{\varepsilon}{1 - \lambda}, \quad \text{and} \quad k < C(n) \cdot \lambda^{-n}.$$

Moreover, these properties are **robust** in the following sense:

Let $\phi_0 = \phi$ and $\phi_i = \phi + c_i$. Let \mathcal{U}_i be the set of contracting maps close to ϕ_i that their contraction bounds are also close to that of ϕ_i . Then the same is true if at each iteration in the \mathcal{G} -orbit of 0 one replace the corresponding ϕ_i by any $\tilde{\phi}_i \in \mathcal{U}_i$.

Remark that if ϕ is smooth, then $D\phi(0)$ may have complex or real eigenvalues (all constants depend to λ which is close to $m(D\phi(0))$).

In order to prove this proposition, we start with a non-perturbative version of it, which also clarifies the robustness of transitivity.

Definition 2.4. We say that an iterated function system $\mathcal{G}(\phi_1, \dots, \phi_k)$ of contracting maps has the *covering property* if there is a open set \mathcal{D} such that

$$\mathcal{D} \subset \bigcup_{i=1}^k \phi_i(\mathcal{D}).$$

The set of (unique) fixed points z_i 's of ϕ_i 's is *well-distributed* if any open ball of diameter d and centered in \mathcal{D} contains some z_i , where

$$d \geq \lambda^{-1} \cdot \max\{r \mid \forall x \in \mathcal{D}, \exists i, B_r(x) \subset \phi_i(\mathcal{D})\}$$

and λ is the minimum of the contraction bounds of ϕ_i 's.

Proposition 2.5. *Let $\phi_i : \mathbb{R}^n \rightarrow \mathbb{R}^n$, $i = 1, 2, \dots, k$, be contracting maps, and $\phi_i(z_i) = z_i$ be their unique fixed points. Suppose that the iterated function system $\mathcal{G} = \mathcal{G}(\phi_1, \dots, \phi_k)$ has covering property on \mathcal{D} . Then for any $x \in \mathcal{D}$ there exists a*

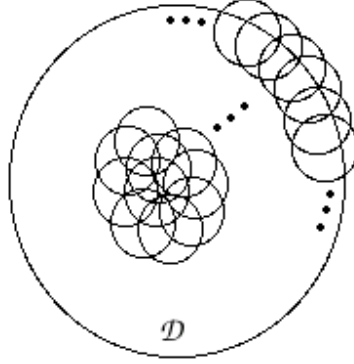

Figure 2.1: The covering and well-distributed properties. The disk \mathcal{D} is the largest one and the other disks are its images under ϕ_i 's.

sequence $\{\sigma_j\}_{j=1}^{\infty}$ such that for all $j \in \mathbb{N}$, $\sigma_j \in \{1, 2, \dots, k\}$, and

$$\phi_{\sigma_j}^{-1} \circ \phi_{\sigma_{j-1}}^{-1} \circ \dots \circ \phi_{\sigma_1}^{-1}(x) \in \mathcal{D}.$$

In addition, if the set $\{z_i\}_{i=1}^k$ is well-distributed in \mathcal{D} then

$$\mathcal{D} \subset \overline{\text{Orbit}_{\mathcal{G}}^+(0)}.$$

Proof. To prove the first part notice that given a point $x \in \mathcal{D}$, the covering property says that there is $\sigma_1 \in \{1, 2, \dots, k\}$ such that $\phi_{\sigma_1}^{-1}(x) \in \mathcal{D}$. Then, inductively, one constructs a sequence $\{\sigma_j\}_{j=1}^{\infty}$ such that $\phi_{\sigma_j}^{-1} \circ \phi_{\sigma_{j-1}}^{-1} \circ \dots \circ \phi_{\sigma_1}^{-1}(x) \in \mathcal{D}$.

Now we prove the second part. The well-distributed property yields that for any small ball $B_r(x_0)$ in \mathcal{D} , either it belongs to some $\phi_i(\mathcal{D})$ or it contains the fixed point of some ϕ_i . Now, If the ball $B_r(x_0)$ is very small then it belongs to the domain of some ϕ_i , i.e. $B_r(x_0) \subset \phi_i(\mathcal{D})$, and so there is $x_1 \in \mathcal{D}$ such that $B_{\lambda^{-1}r}(x_1) \subset \phi_i^{-1}(B_r(x_0)) \subset \mathcal{D}$. We may continue this process inductively. Since, the ratio of the balls is increasing exponentially, after some iteration, it would be large enough to contain the fixed point of some ϕ_i . This completes the proof. \square

Remark 2.6. The well-distributed property yields that for any small ball $B_r(x_0)$ in \mathcal{D} ,

either it belongs to some $\phi_i(\mathcal{D})$ or it contains the fixed point of some ϕ_i . The latter case could be weakened to “or it contains some few \mathcal{G} -iterations of the fixed point of some ϕ_i ”.

Proof of Proposition 2.3. It is enough to show that there exist a number k , and certain (small) translations of the map ϕ , the covering property and the well-distributed hypothesis holds in some open ball $B_\varepsilon(0)$. Then using Proposition 2.5 we obtain the density of \mathcal{G} -orbit of 0. It is not difficult to see that $k < C(n) \cdot \lambda^{-n}$. The persistency follows the fact that the covering property and the well-distributed hypothesis are C^0 robust properties if the contraction bounds of the nearby maps are close to the initial ones. □

2.2 Recurrent diffeomorphisms

In this section we study the transitivity for the iterated function system of recurrent diffeomorphisms. The results of this section shall be used in the proof of the main theorem.

Let us first recall some definitions. An orbit is said quasi periodic if its closure \mathcal{T} is diffeomorphic to a torus and the dynamics on \mathcal{T} is conjugate to an irrational rotation on the torus.

A Hamiltonian on a $2n$ -dimensional manifold is called *completely integrable* if it has n integrals in involution. Recall that an integral is a smooth real function on N (or $N \times \mathbb{R}$ in the case of time dependent Hamiltonian) which is constant along the orbits of the Hamiltonian flow. A Hamiltonian is called *integrable* if it is locally completely integrable. A diffeomorphism is called integrable if it is the time-one map of some integrable Hamiltonian flow.

Liouville-Arnold Theorem says that if $f \in \text{Diff}_\omega^r(N)$ is integrable then $N = \overline{\cup N_i}$, where

- N_i 's are mutually disjoint open sets,
- for any i , N_i is invariant and diffeomorphic to $\mathbb{D}^n \times \mathbb{T}^n$ by a diffeomorphism h_i ,
- any torus $h_i^{-1}(\{x\} \times \mathbb{T}^n)$ is f -invariant and its dynamics is conjugate to a rotation.

We may also suppose that

- the family $\{N_i\}$ is locally finite in N .

Lemma 2.7. *Let f_1 be an integrable symplectic diffeomorphism on the symplectic manifold N . Then arbitrarily close to f_1 there exists another integrable symplectic diffeomorphism f_2 which is conjugated to f_1 by a smooth change of coordinates on N such that*

1. any f_1 -invariant torus intersects transversally some f_2 -invariant torus, and vice versa,
2. given two open sets $U, V \subset N$, there is a chain of tori \mathcal{T}_j , $j = 1, 2, \dots, s$, invariant for f_{σ_j} , $\sigma_j = 1$ or 2 , such that, each \mathcal{T}_j , ($j < s$), intersects transversally \mathcal{T}_{j+1} , \mathcal{T}_1 intersects U and \mathcal{T}_s intersects V .

Proof. We construct a symplectic diffeomorphism $\phi \in \text{Diff}_\omega^r(N)$ close to the identity such that $f_2 = \phi \circ f_1 \circ \phi^{-1}$ has the desired properties. As mentioned before, $N = \cup \overline{N_i}$, where N_i is diffeomorphic to $\mathbb{D}^n \times \mathbb{T}^n$ by a diffeomorphism h_i . It is convenient to consider the polar coordinate system on $\mathbb{D}^n \times \mathbb{T}^n$, that is, any point is represented by

$$(r_1, \dots, r_n, \theta_1, \dots, \theta_n),$$

where $0 \leq r_i < 1$ and $\theta_i \in \mathbb{T}$.

The construction of ϕ has two steps.

Step 1. Let $\psi_1 \in \text{Diff}_\omega^r(\mathbb{R}^2)$ be the time one map an integrable Hamiltonian flow such that in the polar coordinate we have

- $\psi_1(r, \theta) = (r, \theta)$, if $r \geq 1$,
- $\psi_1(\{r = c\}) \neq \{r = c\}$, if $1 > c \geq 0$,
- any two open set in the unit disk $\{r < 1\}$ are connected by a chain of circles $\{r = c_j\}$ and $\psi_1(\{r = c_i\})$.

Note that it is not difficult to define ψ_1 explicitly. Now let

$$\psi = \overbrace{\psi_1 \times \cdots \times \psi_1}^{n \text{ times}}.$$

Define $\varphi \in \text{Diff}_\omega^r(N)$ by

$$\varphi = \begin{cases} h_i^{-1} \circ \psi \circ h_i & \text{on } N_i \\ id & \text{on } N \setminus \cup N_i \end{cases}$$

The smoothness of φ on each N_i is trivial, and on the boundary of N_i 's follows from the fact that N_i 's are a locally finite family in N , they are mutually disjoint and ψ is equal to the identity on the boundary of $\mathbb{D}^n \times \mathbb{T}^n$.

Step 2. Let $i > j$ such that $\partial N_i \cap \partial N_j$ contains a regular hypersurface (codimension one) S_{ij} . Then for any such i, j we consider a small open neighborhood U_{ij} of some point of the hypersurface S_{ij} . The sets U_{ij} are pairwise disjoint. Let $U_{ij}^+ = U_{ij} \cap N_i$ and $U_{ij}^- = U_{ij} \cap N_j$. Then consider a symplectic diffeomorphism φ_{ij} supported in U_{ij} such that

$$\varphi_{ij}(U_{ij}^-) \cap U_{ij}^+ \neq \emptyset \text{ and } \varphi_{ij}(U_{ij}^+) \cap U_{ij}^- \neq \emptyset.$$

Now we take the composition of the all the above diffeomorphisms to define $\phi \in \text{Diff}_\omega^r(N)$, that is

$$\phi := (\circ_{ij} \varphi_{ij}) \circ \varphi.$$

It is not difficult to see that $f_2 = \phi \circ f_1 \circ \phi^{-1}$ has the desired properties. \square

Proposition 2.8. *Let T_1 be an integrable symplectic diffeomorphism on the symplectic manifold N . Then arbitrarily close to T_1 there exists an integrable symplectic diffeomorphism T_2 on N such that the iterated function system $\mathcal{G}(T_1^d, T_2^{d'})$ has a dense orbit, for any $d, d' \in \mathbb{Z}$. Moreover, almost all points have dense \mathcal{G} -orbits.*

Proof. Let T_2 be some integrable diffeomorphism. Let \mathcal{S}_0 be the set of all quasi periodic points for T_1 , which is T_1 -invariant. Similarly, let \mathcal{S}'_0 the set of all quasi periodic points for T_2 , which is T_2 -invariant. It follows that the complements of \mathcal{S}_0 and \mathcal{S}'_0 have zero Lebesgue measure, and Lebesgue measure is invariant under T_1 and T_2 . Let \mathcal{S} the set of all points whose orbits under the iterated function system $\mathcal{G}(T_1, T_2)$ belong to $\mathcal{S}_0 \cap \mathcal{S}'_0$.

CLAIM. The set \mathcal{S} has total Lebesgue measure.

Proof of Claim. We use an inductive process. Let the sequence of sets \mathcal{S}_k and \mathcal{S}'_k , $k \in \mathbb{N}$ defined as the following:

$$\mathcal{S}_{k+1} := \bigcap_{n \in \mathbb{Z}} T_1^n(\mathcal{S}'_k),$$

$$\mathcal{S}'_{k+1} := \bigcap_{n \in \mathbb{Z}} T_2^n(\mathcal{S}_k).$$

By the definitions, \mathcal{S}_k is T_1 -invariant and \mathcal{S}'_k is T_2 -invariant. The complements of these sets have zero Lebesgue measure. Furthermore, if $x \in \mathcal{S}_k$ then for all $n, m \in \mathbb{Z}$, $T_2^m \circ T_1^n(x) \in \mathcal{S}'_{k-1}$, since $\mathcal{S}_k \subset \mathcal{S}'_{k-1}$. So \mathcal{S}_k contains the set of all points in N whose first k -th iterations under $\mathcal{G}(T_1^d, T_2^{d'})$ belong to \mathcal{S}_0 , for any $d, d' \in \mathbb{Z}$. More precisely,

$$\mathcal{S}_k = \{x \in N \mid \forall n_1, m_1, \dots, n_k, m_k \in \mathbb{Z}, T_2^{n_k} \circ T_1^{m_k} \circ \dots \circ T_2^{n_1} \circ T_1^{m_1}(x) \in \mathcal{S}_0\}.$$

This shows that $\mathcal{S} = \bigcap_{k=0}^{\infty} \mathcal{S}_k$. The complement of this set has zero Lebesgue measure.

This completes the proof of the claim.

Now we apply Lemma 2.7 for T_1 . Then we obtain $\phi \in \text{Diff}_\omega^r(N)$ close to the identity. Now we set $T_2 := \phi \circ T_1 \circ \phi^{-1}$. Then given two open sets U, V , there is a chain of tori \mathcal{T}_j , $j = 1, 2, \dots, s$, invariants for T_{σ_j} , $\sigma_j = 1$ or 2 , such that, each \mathcal{T}_j intersects (transversally) \mathcal{T}_{j+1} , \mathcal{T}_1 intersects U and \mathcal{T}_s intersects V . It is not difficult to find an orbit of \mathcal{G} which shadows this chain. For any $z \in \mathcal{S}$, there is n_z such that $T_{\sigma_j}^{n_z}(z)$ is close to \mathcal{T}_{j+1} if z is sufficiently close to \mathcal{T}_j . The set \mathcal{S} is $\mathcal{G}(T_1, T_2)$ -invariant. So if $z \in \mathcal{S}$ is sufficiently close to \mathcal{T}_1 , then it has a \mathcal{G} -orbit shadowing all \mathcal{T}_j , and therefore there is an orbit from U to V . Moreover, given any point $x \in \mathcal{S}$ and any open set U , there is a finite sequence of tori \mathcal{T}_i , $i = 1, \dots, n$, invariant for T_1 or T_2 (alternatively), such that $x \in \mathcal{T}_1$, $\mathcal{T}_n \cap U \neq \emptyset$, and for any i , \mathcal{T}_i intersects transversally \mathcal{T}_{i+1} . Then it follows that there exists $\Sigma = (\sigma_1, \dots, \sigma_m)$ such that $T_\Sigma(x) \in U$. This completes the proof. \square

Remark 2.9. If the set of quasi periodic points is residual then following the same argument in the proof, we conclude that the set of all points with dense orbit for $\mathcal{G}(T_1, T_2)$ is also residual.

Remark 2.10. The change of coordinates could be chosen to be an analytic exact Hamiltonian diffeomorphism, however it required a non-local proof. Moreover, it could be close to the identity map even in the strong Whitney topology.

Example 2.11. Let $N = \mathbb{R} \times (\mathbb{R}/2\pi\mathbb{Z})$ and

$$T_1 : (I, \theta) \longmapsto (I, \theta + h(I)).$$

In this case, we choose the change of coordinates

$$\phi : (I, \theta) \longmapsto (I + \epsilon \cos \theta, \theta).$$

And then we define $T_2 = \phi \circ T_1 \circ \phi^{-1}$. Now the above argument works well.

Now, we establish a result about recurrent diffeomorphism. Recall that, by recurrent diffeomorphism we meant that almost all points are recurrent. Poincaré recurrence Theorem yields that conservative diffeomorphisms on compact manifolds are recurrent.

Theorem 2.12. *Let $T \in \text{Diff}_\omega^r(N)$ be a recurrent diffeomorphism. Then for every $\epsilon > 0$,*

1. *there exist $T_1, T_2 \in B_\epsilon(T) \subset \text{Diff}_\omega^r(N)$ such that $\mathcal{G}(T, T_1, T_2)$ is transitive,*
2. *for any open ball $V \subset N$ and any bounded domain $N_c \subset N$, there exist $k \in \mathbb{N}$ and $T_1, T_2, \dots, T_k \in B_\epsilon(T) \subset \text{Diff}_\omega^r(N)$ such that $N_c \subset \text{Orbit}_{\mathcal{G}}^-(V)$, where $\mathcal{G} = \mathcal{G}(T, T_1, T_2, \dots, T_k)$.*

Proof. If $T = id$, then we choose ϕ_1 an integrable symplectic diffeomorphism on the manifold N such that almost all points are quasi periodic, and $d_{C^r}(\phi_1, id) < \frac{1}{2}\epsilon$. Proposition 2.8 implies that for any open set V there exists, ϕ_2 in $\text{Diff}_\omega^r(N)$ and ϵ -close to the identity in the C^r topology, such that, $\text{Orbit}_{\mathcal{G}_\phi}^-(V) \cap \text{Orbit}_{\mathcal{G}_\phi}^+(V)$ is (open and) dense in N , where $\mathcal{G}_\phi = \mathcal{G}(\phi_1, \phi_2)$. In other words, \mathcal{G}_ϕ is transitive. This completes the proof of (1) in the case that $T = id$.

For an arbitrary recurrent T , let \mathcal{R} be the set of recurrent points of T , which is also invariant for ϕ_1 and ϕ_2 . This set is dense. In fact, following an argument similar to the Claim in the proof of Proposition 2.8 this set has total Lebesgue measure (and also is residual).

Let V is an open set in N , and $z \in \mathcal{R} \cap \text{Orbit}_{\mathcal{G}_\phi}^-(V)$. This intersection is obviously non-empty. Then, there are $d \in \mathbb{N}$ and $\Sigma = (\sigma_1, \dots, \sigma_d), \sigma_i = 1, 2$, such that

$$z \in (\phi_\Sigma)^{-1}(V).$$

Moreover, for any $i = 1, 2, \dots, d$, and any $l_j \in \mathbb{Z}$, $j = 1, 2, \dots, i$,

$$\tilde{z}_i := (T^{l_i} \circ \phi_{\sigma_i}) \circ \dots \circ (T^{l_1} \circ \phi_{\sigma_1})(z) \in \mathcal{R}.$$

So, using recurrency, for some (large) $l_j \in \mathbb{N}$, the orbit $(\tilde{z}_i)_i$ shadows $(z_i)_i$, where $z_i = \phi_{\sigma_i} \circ \dots \circ \phi_{\sigma_1}(z)$. This shows that for some $l_j \in \mathbb{N}$, the point \tilde{z}_d belongs to V . But $(\tilde{z}_i)_i$ is an orbit of z under the iterated function system of

$$\mathcal{G}_2 = \mathcal{G}(T, T \circ \phi_1, T \circ \phi_2).$$

In other words, $\tilde{z}_d \in V \cap \mathcal{O}rbit_{\mathcal{G}_2}^+(z)$. Recall that, $\mathcal{R} \cap \mathcal{O}rbit_{\mathcal{G}_\phi}^-(V)$ is dense in N . So, the \mathcal{G}_2 -orbit of any point in a dense set, intersects V . The same is true for backward \mathcal{G}_2 -orbits. Thus, $\mathcal{O}rbit_{\mathcal{G}_2}^\pm(V)$ is (open and) dense in N , and \mathcal{G}_2 is transitive. This completes the proof of (1).

Given $N_c \subset\subset N$ bounded, and $V \subset N$ open, we let $X = \overline{B_1(N_c)} \setminus \mathcal{O}rbit_{\mathcal{G}_2}^-(V)$. X is a compact set with empty interior. So for any $x \in X$ there exists, h_x in $\text{Diff}_\omega^r(N)$ and ϵ -close to the identity in the C^r topology, such that $h_x^{-1}(x) \in V^- := \mathcal{O}rbit_{\mathcal{G}_2}^-(V)$. Since V^- is open, there is a neighborhood U_x of x such that $h_x^{-1}(U_x) \subset V^-$. The family $\{U_x\}$ is open cover of the compact set X . So there exist $k \in \mathbb{N}$, $x_1, x_2, \dots, x_l \in X$ and $h_{x_1}, h_{x_2}, \dots, h_{x_k} \in B_\epsilon(id) \subset \text{Diff}_\omega^r(N)$ such that

$$X \cap h_{x_1}^{-1}(X) \cap \dots \cap h_{x_k}^{-1}(X) = \emptyset.$$

Thus

$$T^{-1}(X) \cap (h_{x_1} \circ T)^{-1}(X) \cap \dots \cap (h_{x_k} \circ T)^{-1}(X) = \emptyset.$$

Therefore,

$$N_c \subset\subset T^{-1}(V^-) \cap (h_{x_1} \circ T)^{-1}(V^-) \cap \dots \cap (h_{x_k} \circ T)^{-1}(V^-).$$

If we define $\mathcal{G} := \mathcal{G}(T, T \circ \phi_1, T \circ \phi_2, h_{x_1} \circ T, \dots, h_{x_k} \circ T)$, then we have

$$N_c \subset \subset \text{Orbit}_{\mathcal{G}}^-(V).$$

□

Remark 2.13. As it has been mentioned, if N is compact or has finite volume, by the Poincaré recurrence Theorem, T is recurrent. For non-compact manifold N with unbounded volume we know that almost all points are either recurrent or converge to infinity. Moreover, in the interior of the non-wandering set of T , generic points (in a residual set) are recurrent. So, when the non-wandering set has (large) non-empty interior, as the same as above, there is an iterated function system of its nearby systems exhibiting transitivity in the interior of the non-wandering set. See also Section 5.1.

2.3 Skew products and IFS

In this section we explain the relation between iterated function systems and skew products over shifts.

Let τ be the full shift with d symbols.

$$\tau : d^{\mathbb{Z}} \rightarrow d^{\mathbb{Z}}$$

$$x = (\dots, x_{-1}, x_0; x_1, \dots) \mapsto (\dots, x_0, x_1; x_2, \dots)$$

It is natural to define the local and global unstable manifolds of a point $x \in d^{\mathbb{Z}}$ for τ as the following

$$W_{loc}^u(x; \tau) = \{(z_i) \mid \forall i \leq 0, z_i = x_i\}$$

$$W^u(x; \tau) = \bigcup_{i \geq 0} \tau^i(W_{loc}^u(\tau^{-i}(x); \tau)) = \{(z_i) \mid \exists i_0 \in \mathbb{Z}, \forall i \leq i_0, z_i = x_i\}.$$

Let $\Phi : d^{\mathbb{Z}} \times Y \rightarrow d^{\mathbb{Z}} \times Y$ be a skew product such that

$$\Phi(x, y) = (\tau(x), \phi_x(y)),$$

such that ϕ_x is a homeomorphism on Y , for any $x \in d^{\mathbb{Z}}$. Assume that the family of ϕ_x 's are uniformly bi-Lipschitz, i.e., there exists $L > 1$ such that $\forall x \in d^{\mathbb{Z}}, \forall y, y' \in Y$,

$$\frac{1}{L} \text{dist}(y, y') \leq \text{dist}(\phi_x(y), \phi_x(y')) \leq L \cdot \text{dist}(y, y').$$

Then one may define the strong unstable manifold as follows.

$$W^{uu}(x, y; \Phi) := \{(a, b) \mid \text{dist}(\Phi^i(x, y), \Phi^i(a, b)) \sim \exp(iL) \text{ as } i \rightarrow -\infty\}.$$

To make this definition appropriate to our purpose we consider the following metric on $d^{\mathbb{Z}}$,

$$\text{dist}(x, z) = \sum_{i \in \mathbb{Z}} e^{-|i|L} |x_i - z_i|.$$

Assume that ϕ_x depends only to $[x_i \mid i \leq i_0]$, and denote it by $\phi_{[x_{\leq i_0}]}$. To avoid complications we also assume that $i_0 = 0$.

Therefore, $\Phi = \tau \times \phi_x$ on the set $\{z \in d^{\mathbb{Z}} \mid z_i = x_i, i \leq 0\} \times Y$. So, the local unstable manifold of (x, y) for Φ contains $W_{loc}^u(x; \tau) \times \{y\}$. Then we have the following proposition.

Proposition 2.14. *For any $(x, y) \in d^{\mathbb{Z}} \times Y$ and $n \in \mathbb{N}$,*

$$\begin{aligned} \Phi^n(x, y) &= (\tau^n(x), \phi_{[x_{\leq n-1}]} \circ \cdots \circ \phi_{[x_{\leq 0}]}(y)), \\ \Phi^{-n}(x, y) &= (\tau^{-n}(x), \phi_{[x_{\leq -n}]}^{-1} \circ \cdots \circ \phi_{[x_{\leq -1}]}^{-1}(y)). \\ W_{loc}^{uu}(x, y; \Phi) &= W_{loc}^u(x; \tau) \times \{y\} = \{(z_i) \mid \forall i \leq 0, z_i = x_i\} \times \{y\}, \\ W^{uu}(x, y; \Phi) &= \bigcup_{i \geq 0} \Phi^i(W_{loc}^{uu}(\Phi^{-i}(x, y); \Phi)). \end{aligned}$$

Since $W_{loc}^{uu}(x, y; \Phi)$ is a product set and Φ is a product on it, so $\Phi^i(W_{loc}^{uu}(x, y; \Phi))$ is a finite union of some local strong unstable manifolds. Therefore, we have the following proposition.

Proposition 2.15. *For any $(x, y) \in d^{\mathbb{Z}} \times Y$, the global strong unstable manifold $W_{loc}^{uu}(x, y; \Phi)$ is a countable union of some local unstable manifolds $W_{loc}^{uu}((x^i, y^i); \Phi)$.*

Locally constant skew products

From now on we assume that ϕ_x depends only to x_0 . Then, $\Phi = \tau \times \phi_j$ on the set $\{z \in d^{\mathbb{Z}} \mid z_0 = j\} \times Y$, for any $j \in \{1, 2, \dots, d\}$. The next propositions shed some light on the relation between (locally constant) skew product over shift and iterated function systems.

Let $\mathcal{G} = \mathcal{G}(\phi_1, \phi_2, \dots, \phi_d)$. Proposition 2.14 implies that for any $(x, y) \in d^{\mathbb{Z}} \times Y$ and $n \in \mathbb{N}$,

$$\Phi^n(x, y) = (\tau^n(x), \phi_{x_{n-1}} \circ \dots \circ \phi_{x_0}(y)).$$

This yields that by taking different base points x , one can realize the orbit of y under the IFS \mathcal{G} . Since the skew product Φ does not depends on x_i , $i > 0$, so we get the entire positive \mathcal{G} -orbit of y by taking all points on $W_{loc}^u(x; \tau)$. So we have the following proposition.

Proposition 2.16. *For any $(x, y) \in d^{\mathbb{Z}} \times Y$, the projection of $\bigcup_{n>0} \Phi^n(W_{loc}^{uu}(x, y; \Phi))$ on Y is equal to $\text{Orbit}_{\mathcal{G}}^+(\phi_{x_0}(y))$. In particular, if (x, y) is a fixed point of Φ , then the projection of $W^{uu}(x, y; \Phi)$ on Y is equal to $\text{Orbit}_{\mathcal{G}}^+(y)$.*

This proposition turns out to be very useful in the study of dynamical properties of strong stable/unstable manifolds of certain partially hyperbolic systems. For instance, to obtain the density of the strong unstable manifold (see §4.3).

Here we just mention the geometrical meaning of this fact. At each iteration of the length of $W_{loc}^{uu}(x, y; \Phi)$ grows exponentially and it intersects the domain of all ϕ_i 's. Therefore, all possible compositions of ϕ_i 's do appear in the positive orbit of $W_{loc}^{uu}(x, y; \Phi)$. Indeed, we have the following proposition which gives a precise description of the global strong unstable manifolds for Φ .

Proposition 2.17. *For any $(x, y) \in d^{\mathbb{Z}} \times Y$,*

$$W^{uu}(x, y; \Phi) = \bigcup_{\sigma \in \Sigma} W_{loc}^{uu}(x^\sigma, \phi^{x, \sigma}(y); \Phi),$$

where

$$\Sigma = \{\sigma = (\sigma_1, \dots, \sigma_n) \mid n \in \mathbb{N}, 1 \leq \sigma_i \leq d\},$$

$$\phi^{x, \sigma} = \phi_{\sigma_{n-1}} \circ \dots \circ \phi_{\sigma_1} \circ \phi_{x_{-n+1}}^{-1} \circ \dots \circ \phi_{x_{-1}}^{-1} \text{ and } \phi^{x, (\sigma_1)} = id,$$

$$x^\sigma = (\dots, x_{-n}, \sigma_1, \dots, \sigma_n; x_1, \dots).$$

Proof. It is easy to see that for any $\sigma, \sigma' \in \Sigma$, $W_{loc}^u(x^\sigma; \tau) = W_{loc}^u(x^{\sigma'}; \tau)$ if and only if $\sigma = \sigma'$. Moreover, $\tau^n(x^\sigma) \in W_{loc}^u(x; \tau)$ if $\sigma = (\sigma_1, \dots, \sigma_n)$. Therefore,

$$W^u(x; \tau) = \bigcup_{\sigma \in \Sigma} W_{loc}^u(x^\sigma; \tau).$$

On the other hand, the projection of $W^{uu}(x, y; \Phi)$ on $d^{\mathbb{Z}}$ is equal to $W^u(x; \tau)$, since Φ is skew product.

$$\begin{aligned} W^{uu}(x, y; \Phi) &= \bigcup_{n \geq 0} \Phi^n(W_{loc}^{uu}(\Phi^{-n}(x, y); \Phi)) \\ \Phi(W_{loc}^{uu}(\Phi^{-1}(x, y); \Phi)) &= \Phi(W_{loc}^u(\tau^{-1}(x); \tau) \times \{\phi_{x_{-1}}^{-1}(y)\}) \\ &= (\tau \times \phi_{x_{-1}})(W_{loc}^u(\tau^{-1}(x); \tau) \times \{\phi_{x_{-1}}^{-1}(y)\}) \\ &= \tau(W_{loc}^u(\tau^{-1}(x); \tau)) \times \{y\} \end{aligned}$$

Then,

$$\Phi(W_{loc}^{uu}(\Phi^{-1}(x, y); \Phi)) = \bigcup_{|\sigma|=1} W_{loc}^{uu}(x^\sigma, y; \Phi).$$

From the definition of global unstable manifolds and Proposition 2.14 it follows that for any $n \in \mathbb{N}$,

$$\begin{aligned} \Phi^n(W_{loc}^{uu}(p, q; \Phi)) &= \bigcup_{a \in W_{loc}^u(p; \tau)} \{(\tau^n(a), \phi_{a_{n-1}} \circ \cdots \circ \phi_{a_0}(q))\} \\ &= \bigcup_{\substack{\eta=(p_0, a_1, \dots, a_{n-1}) \\ a=(\dots, p_0; a_1, a_2, \dots)}} \{(\tau^n(a), \phi_\eta(q))\} \end{aligned}$$

Now let $(p, q) = \Phi^{-n}(x, y)$, then $p_i = x_{i-n}$, ($\forall i \in \mathbb{Z}$), and $q = \phi_{x_{-n}}^{-1} \circ \cdots \circ \phi_{x_{-1}}^{-1}(y)$. Thus, $\tau^n(a) = (\dots, p_0, a_1, \dots, a_n; a_{>n}) = (\dots, x_{-n}, a_1, \dots, a_n; a_{>n})$ and $\eta = (x_{-n}, a_1, \dots, a_{n-1})$.

Therefore,

$$\begin{aligned} \phi_\eta(q) &= \phi_{\eta_n} \circ \cdots \circ \phi_{\eta_1} \circ \phi_{x_{-n}}^{-1} \circ \cdots \circ \phi_{x_{-1}}^{-1}(y) \\ &= \phi_{a_{n-1}} \circ \cdots \circ \phi_{a_1} \circ \phi_{x_{-n}} \circ \phi_{x_{-n}}^{-1} \circ \phi_{x_{-n+1}}^{-1} \circ \cdots \circ \phi_{x_{-1}}^{-1}(y) \\ &= \phi_{a_{n-1}} \circ \cdots \circ \phi_{a_1} \circ \phi_{x_{-n+1}}^{-1} \circ \cdots \circ \phi_{x_{-1}}^{-1}(y). \end{aligned}$$

It yields that,

$$\begin{aligned} \Phi^n(W_{loc}^{uu}(\Phi^{-n}(x, y); \Phi)) &= \bigcup_{\substack{\eta=(p_0, a_1, \dots, a_{n-1}) \\ a=(\dots, p_0; a_1, a_2, \dots)}} \{(\tau^n(a), \phi_\eta(q))\} \\ &= \bigcup_{|\sigma|=n} W_{loc}^{uu}(x^\sigma, \phi^{x, \sigma}(y); \Phi). \end{aligned}$$

This completes the proof. □

The stable manifolds for these maps are defined as the unstable manifolds of corresponding inverse maps. Similar results hold for stable manifolds.

Chapter 3

Symplectic blender

Definition, existence and properties of symplectic double blenders are discussed in this chapter.

Bonatti and Díaz in [BD] introduced blenders, geometric models for certain hyperbolic sets originated in the unfolding of heterodimensional cycles, that play an important role as a mechanism for creation of cycles, and semi-local source of transitivity. Although their methods may be modified for the conservative case, the symplectic case is more delicate.

In [BD] a *cs*-blender, roughly speaking, is a hyperbolic (locally maximal) invariant set with a splitting of the form $E^{ss} \oplus E^u \oplus E^{uu}$, $\dim E^u = 1$, such that a convenient projection of its stable set has larger topological dimension than the stable set itself. This phenomenon is robust in the C^1 topology. Similarly, one may define *cu*-blender.

Their constructions essentially use a hyperbolic set with a one-dimensional weakly hyperbolic subbundle. On the other hand, to apply this local tool for systems with higher dimensional central bundles they use a chain of blenders with one-dimensional central bundles and different indices (i.e. dimension of the stable bundle) connected to each other. This allows them to use such blenders in more situations. This is of course impossible in the symplectic case, since all eigenvalues are pairwise conjugate

and so all hyperbolic periodic points have the same index. *So in the symplectic case we involve higher central dimensions in the creation of a blender.* We construct a new class of such blenders in the symplectic (or Hamiltonian) systems that work like a chain of *cs*-blenders and a chain of *cu*-blenders simultaneously.

In section 3.1, regardless of the symplectic case, we study blenders with higher central dimensions when the central bundle is uniformly unstable (stable, respectively) and we construct a *cs*-blender (*cu*-blender, respectively). In section 3.2, we consider the case that the central bundle splits into two stable and unstable subbundles, that is, the maximal invariant set is hyperbolic of the form $E^{ss} \oplus E^s \oplus E^u \oplus E^{uu}$, and we create a blender which exhibits the features of both *cu*- and *cs*- blenders. We call it *double-blender*. Note that this case is very compatible with the symplectic case where the eigenvalues of periodic points are pairwise conjugate. In section 3.3, we study the symplectic case, and we introduce the symplectic version of the above phenomenon, which we call *symplectic blender*.

Let us state here a formal definition of symplectic and double blenders.

Definition 3.1. Let \mathcal{B} is an open embedded ball on which there are four invariant cone-fields \mathcal{C}^{ss} , \mathcal{C}^s , \mathcal{C}^u , \mathcal{C}^{uu} , invariant under the derivative DF . A vertical strip (or *u*-strip) is an embedded (*u*)-dimensional disk in \mathcal{B} , which contains the *uu*-leaves of each its points. Similarly we define horizontal strip (or *s*-strip).

Definition 3.2. The pair (P, \mathcal{B}) is a double blender for the diffeomorphism F if satisfies the following features:

B-1 P is a hyperbolic saddle periodic point of F .

B-2 \mathcal{B} is an open embedded ball on which there are four cone fields \mathcal{C}^{ss} , \mathcal{C}^s , \mathcal{C}^u , \mathcal{C}^{uu} , invariant under the derivative DF .

B-3 For any G sufficiently close to F in the C^1 topology, the stable manifold of P_G intersects any *u*-strip in \mathcal{B} , and the unstable manifold of P_G intersects any

s -strip in \mathcal{B} . Here P_G is the continuation of P .

Definition 3.3. A *symplectic blender* is a double blender for a symplectic (or Hamiltonian) diffeomorphism.

In order to give a more clear picture of the dynamics of the above phenomena we start by a simple affine model for each one and then we relax the construction to the more flexible versions, robust under C^1 small perturbations, which is the subject of section 3.4. In fact, we may also define blenders in another way which takes in to account their construction, rather than their properties (see also [BDV, chapter 6]).

Throughout this section we consider the diffeomorphism f of \mathbb{R}^2 which is the Smale horseshoe on $U := [0, 1]^2$ and is of the form that follows.

The vertical sub-rectangles $X_1 = I_1 \times [0, 1]$ and $X_2 = I_2 \times [0, 1]$ are connected components of $f(U) \cap U$ and also the horizontal sub-rectangles $Y_1 = f^{-1}(X_1)$ and $Y_2 = f^{-1}(X_2)$ are connected components of $f^{-1}(U) \cap U$. The restrictions of f to Y_1 and to Y_2 are affine maps with linear part

$$\begin{pmatrix} \pm\frac{1}{4} & 0 \\ 0 & \pm 4 \end{pmatrix}.$$

From now on we suppose $x \in E^{ss}$, $y \in E^{uu}$, associated to f and we denote by (x_0, y_0) the unique fixed point of f in X_1 .

3.1 cs -blender with higher dimensional unstable central bundle

The following proposition about the iterated function system of expanding maps is a special case of Proposition 2.3.

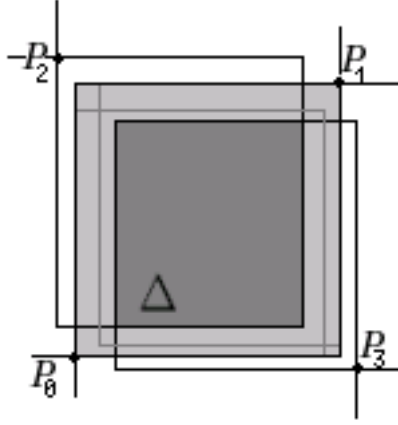

Figure 3.1: IFS of expanding maps

Proposition 3.4. For $i = 0, 1, 2, 3$, let $g_i(x, y) := (a_i x + b_i, c_i y + d_i)$ where $1 < a_i = c_i = \frac{16}{15} < 2$ and b_i, d_i 's are such that the fixed points of g_0, \dots, g_3 are respectively, $P_0 = (0, 0), P_1 = (1, 1), P_2 = (-0.1, 1.1), P_3 = (1.1, 0.1)$. See Figure 1. Given any open rectangle $\Sigma \subset [0, 1]^2$ there is $g_\sigma \in \mathcal{G}(g_1, g_2, g_3, g_4)$ such that $(0, 0) \in g_\sigma(\Sigma)$. This property persists for all (uniformly) expanding maps \tilde{g}_i close to g_i if their expansion bounds (i.e. the contraction bounds of \tilde{g}_i^{-1}) are also close to those of g_i 's.

Now, consider the diffeomorphism F of \mathbb{R}^4 such that in $B := [-1, 1]^2 \times [0, 1]^2$ is of the form:

$$F(p, q; x, y) := (g_i(p, q); f(x, y)), \text{ if } (x, y) \in B_i \text{ and } (p, q) \in [-1, 1]^2,$$

where $B_1 = X_1 \cap Y_1, B_2 = X_2 \cap Y_2, B_3 = X_1 \cap Y_2, B_4 = X_2 \cap Y_1$, and g_i 's are the expanding maps taken in Proposition 3.4. Observe that $F(B) \cap B$ contains the four boxes $[-1, 1] \times [-1, 1] \times X_1, [-1, \frac{3}{4}] \times [-1, 1] \times X_1, [-1, 1] \times [-1, \frac{3}{4}] \times X_2$ and $[-1, \frac{3}{4}] \times [-1, \frac{3}{4}] \times X_2$ and that $Q = (0, 0, x_0, y_0)$ is the (unique) hyperbolic fixed saddle of F of index 3. Let $W_{loc}^s(Q) = \{0\} \times \{0\} \times [0, 1] \times \{y_0\}$ be the connected component of $W^s(Q) \cap B$ that contains Q .

Definition 3.5. A vertical strip with respect to Q , or simply vertical strip, is a rectangle

$\Delta = \bar{\Sigma} \times \{x\} \times [0, 1]$, where $x \in [0, 1]$ and $\bar{\Sigma}$ is a closed rectangle (with non-empty interior) in $[0, 1]^2$.

The next proposition gives the main geometric property of *cs-blender*.

Proposition 3.6. *Every vertical strip Δ with respect to Q intersects $W^s(Q)$.*

Proof. This proposition may be reduced to the transitivity of the iterated function system $\mathcal{G}(g_0, g_1, g_2, g_3)$. Any vertical strip intersects all B_i 's, and the map F restricted to each of B_i is equal to $g_i \times f$. The image of any vertical strip Δ contains a union of four vertical strips Δ_j each of which intersects all B_i s. So the \mathcal{G} -orbit of $(0, 0)$ corresponds to some points in $W^s(Q)$, and is the same as the projection of $W^s(Q)$ to the central direction along the $E^s \oplus E^{uu}$. Proposition 3.4 shows that the orbit of $(0, 0)$ is dense in $[0, 1]^2$. This means that the projection of $W^s(Q)$ to the central direction along the $E^s \oplus E^{uu}$ is dense in $[0, 1]^2$. So $W^s(Q)$ intersects every vertical strip Δ . \square

The following is a direct consequence of the above proposition:

Proposition 3.7. *Suppose that there is a hyperbolic periodic point P of F of index 1 whose one-dimensional unstable manifold crosses B along a vertical segment $\gamma := \{p\} \times \{q\} \times \{x\} \times [0, 1]$ such that $p, q \in (0, 1)$. Then $W^s(P) \subset \overline{W^s(Q)}$.*

Proof. For any open set U that intersects $W^s(P)$, the inclination Lemma yields that there exists some positive integer n such that $F^n(U)$ approximates a compact part of $W^s(P)$ which contains γ . In particular, $F^n(U)$ contains a vertical strip w.r.t. Q in B . Proposition 3.6 implies that $W^s(Q)$ intersects $F^n(U)$ and so it intersects U . This shows that $W^s(Q)$ accumulates to any point in $W^s(P)$. \square

Thus the one-dimensional stable manifold of Q looks like a 3-dimensional manifold, as its closure contains the 3-dimensional manifold $W^s(P)$.

3.2 Double-blender: affine model

In the 3-dimensional *cs*-blenders, if one projects the cube and its pre-image along of stable direction a figure like Smale horseshoe appears but two right and left rectangles overlap, while in the projections along the weak unstable direction do not overlap. Having this in mind, consider a 4-dimensional horseshoe with the splitting of the form $E^{ss} \oplus E^s \oplus E^u \oplus E^{uu}$ such that the projection along E^{ss} give a figure like 3-dimensional horseshoe but its two wings overlapping and the same feature for the inverse map and E^{uu} . This led us to the following affine model.

Consider the following maps on \mathbb{R} , which are maps in central bundle

$$\begin{aligned}\psi_1(p) &:= \frac{4}{5}p & \varphi_1(q) &:= \frac{5}{4}q \\ \psi_2(p) &:= \frac{4}{5}p + \frac{2}{5} & \varphi_2(q) &:= \frac{5}{4}q - \frac{1}{2}\end{aligned}$$

Note that $\varphi_i := \psi_i^{-1}$, and $(p, q) \in E^c$.

Let F be a diffeomorphism on \mathbb{R}^4 such that in $B := [-1, 1]^2 \times [0, 1]^2$ is of the following form:

$$F(p, q; x, y) := (\psi_i(p), \varphi_j(q); f(x, y)), \quad \text{if } (x, y) \in X_i \cap Y_j \text{ and } (p, q) \in [-1, 1]^2.$$

The dynamics of F inside the box B is hyperbolic, $E^{ss} \oplus E^s \oplus E^u \oplus E^{uu}$. The maximal invariant set in B , i.e., $\Lambda = \bigcap F^n(B)$ is a *cs*-blender, if we consider $E^{ss} \oplus E^s$ as stable direction, E^u as central and E^{uu} as strong unstable directions. Similarly Λ is a *cu*-blender if we consider E^{ss} as strong stable direction, E^s as central and $E^u \oplus E^{uu}$ as unstable directions. Therefore Λ is a double-blender. Note that using the results of the previous section, we may consider multi-dimensional central bundle, i.e., both of weak stable and unstable bundles of arbitrary dimension ≥ 1 .

3.3 Symplectic blender: affine model

We consider the following maps on \mathbb{R} , which are maps in central bundle

$$\psi(p) := \lambda p, \quad \varphi(q) := \frac{1}{\lambda}q,$$

where $1 - \lambda > 0$ is small enough.

The symplectic diffeomorphism F on \mathbb{R}^4 is defined as the product of the above maps:

$$F(p, q; x, y) := (\psi(p), \varphi(q); f(x, y)).$$

We shall perturb F by the time-one map of the flow of a Hamiltonian vector field such that the resulting map is a diffeomorphism with the properties of the model in the previous section.

Let α and β be smooth bump functions on \mathbb{R} such that for all $t \in \mathbb{R}$, $0 \leq \alpha(t) \leq 1$, and

$$\alpha(t) = 1 \text{ if } t \in I_1 \cup I_2 \text{ and } \alpha(t) = 0 \text{ if } t \notin J_1 \cup J_2,$$

where J_1 and J_2 are disjoint neighborhoods of I_1 and I_2 , respectively.

Similarly, for all $t \in \mathbb{R}$, $0 \leq \beta(t) \leq 1$, and $\beta(t) = 1$ if $t \in [-1, 1]$ and $\beta(t) = 0$ if $t \notin [-\frac{3}{2}, \frac{3}{2}]$.

We define $F_\varepsilon := \Phi_\varepsilon \circ F$, where Φ_ε is the time-one map of the flow associated to the Hamiltonian

$$H_\varepsilon := \varepsilon \alpha(x) \alpha(y) \beta(p) \beta(q) ((i-1)p - (j-1)q), \quad \text{if } x \in J_i \text{ and } y \in J_j, \quad i, j \in \{1, 2\}.$$

The support of H_ε is the disjoint union of four boxes of dimension 4. Then we have the following

Theorem 3.8. *Let F_ε be the Hamiltonian diffeomorphism as defined above. If $\varepsilon > 1 - \lambda > 0$ are small enough, then F_ε has the form of the affine model of double blender and so the maximal invariant set for F_ε inside the $B := [-1, 1]^2 \times [0, 1]^2$ is a symplectic double-blender.*

3.4 Symplectic blender: general construction

We use cone-field structures to make sure that the feature that we explained in the affine cases remains for all nearby systems.

In the above affine models we have four cone fields $\mathcal{C}^{ss}, \mathcal{C}^s, \mathcal{C}^u, \mathcal{C}^{uu}$, invariant under the derivative DF . These cone fields will define invariant foliations in the box B . Of course, these foliations in the affine models coincide with the vertical and horizontal segments and strips. We may repeat all the above process by replacing these vertical and horizontal segments with the almost vertical/horizontal strips/segments, and reducing the iterated function system in central bundles.

Now we prove the robustness of the main features of blenders. We know that these cone fields remain invariant for any C^1 nearby system G . So for nearby systems we will have almost vertical/horizontal strips/segments. These almost vertical/horizontal segments allow us to introduce the corresponding iterated function systems of expanding/contracting maps in central bundles. The new iterated function systems are close to the initial ones, and so thanks to the results of section 2.1, we have robustness of transitivity property of iterated function system of such expanding maps. Therefore the dynamical feature of blender appears also for any G in a C^1 neighborhood of F .

We summarize this section in the following theorem (see also section 4.2).

Theorem 3.9. *Let M and N be two symplectic manifolds (not necessarily compact). Let $r = 1, 2, \dots, \infty$. Suppose that $f_1 \in \text{Diff}_\omega^r(M)$ has a hyperbolic periodic point p_1 with transversal homoclinic intersections and $f_2 \in \text{Diff}_\omega^r(N)$ has a hyperbolic periodic*

point p_2 such that its hyperbolicity is weak enough. Then, there is a C^r -arc $\{F_\mu\}_{\mu \in [0,1]}$ of C^r symplectic diffeomorphism on $M \times N$ such that,

1. $F_0 = f_1 \times f_2$.
2. There is a neighborhood \mathcal{V} of $\{F_\mu\}_{\mu \in (0,1]}$ in $\text{Diff}^1(M \times N)$ such for any $G \in \mathcal{V}$, the pair (P_G, \mathcal{B}) is a double blender, where P_G is the continuation of hyperbolic $P_0 = (p_1, p_2)$ and \mathcal{B} is an embedded open disk in $M \times N$.

Note that, this is not the only way to create blenders. In fact, one may create them by a perturbation of a system exhibiting a quasi transversal homoclinic or heteroclinic intersection, by the similar ways, but with more technical details (see [BD] and [N]). Here we only considered the case where the unperturbed system is a product of two systems, one of them with a transversal homoclinic intersection and the other one with a hyperbolic saddle with weak hyperbolicity. Because it is sufficient for the proof of our main theorems.

Chapter 4

Proof of Theorem A

In this chapter we give the proof of Theorem A. The proof is constructive. It is divided in five parts. First we introduce the perturbations in Section 4.1. Then in the four sequel sections we prove that the perturbed systems satisfy the desired properties. In Section 4.2 we prove the existence of a symplectic blender. Then in Section 4.3 we use the results of iterated function systems of recurrent diffeomorphisms (Section 2.2) to prove that the strong stable and unstable manifolds of almost all points in the central manifold intersects the constructed blender. In Section 4.4 we show that this property is robust under small perturbation, and here we use the dynamical properties of the blender. Then we complete the proof in Section 4.5 by proving that there is a hyperbolic periodic point such that its stable and unstable manifolds are both dense in the set $\Lambda \times N$ in a robust way, concluding the robustly topological mixing.

4.1 The perturbations

Let $r = 1, 2, \dots, \infty$, $f_1 \in \text{Diff}_\omega^r(M)$ and $f_2 \in \text{Diff}_\omega^r(N)$ as in Theorem A. Let $U \subset M$ be a small simply connected open set, such that for some $k \in \mathbb{N}$, $\Lambda := \bigcap_{n \in \mathbb{Z}} f_1^{kn}(U)$ is an invariant hyperbolic compact set for f_1^k . By choosing U suitable and k large enough, we may suppose that $f_1^k|_\Lambda$ is conjugate to a shift of d symbols $\{1, \dots, d\}$.

The required number d of symbols in the proof depends to $\dim N$ and $f_1 \times f_2$. By taking f_1^k , and f_2^k instead of f_1 and f_2 , we may assume that Λ is f_1 -invariant and $\Lambda := \bigcap_{n \in \mathbb{Z}} f_1^n(U)$ is conjugate to a shift of symbols $\{1, \dots, d\}$, where d is sufficiently large. We identify the set identify Λ with that set $\{1, \dots, d\}^{\mathbb{Z}}$.

In order to define our local perturbation we first consider open sets \mathcal{A}_{ij} and pairwise disjoint open sets $\tilde{\mathcal{A}}_{ij}$ in the way that

$$\mathcal{A}_{ij} \cap \Lambda = \{(x_i)_{i \in \mathbb{Z}} \mid x_0 = i, x_1 = j\} \text{ and } \mathcal{A}_{ij} \subset \tilde{\mathcal{A}}_{ij}.$$

In a similar way we define $\mathcal{A}_{\mathcal{I}}$ and $\tilde{\mathcal{A}}_{\mathcal{I}}$ as neighborhoods of $\mathcal{I}^{\mathbb{Z}}$, where $\mathcal{I} \subset \{1, 2, \dots, d\}$. In addition we set $\mathcal{A}_{i,*} = \cup_j \mathcal{A}_{ij}$.

By the assumptions, f_2 has a δ -weak hyperbolic periodic point p_2 , for some positive $\delta = \delta(f_1, f_2)$ close to zero. Suppose that $T_{p_2}N = E_{p_2}^s \oplus E_{p_2}^u$. We consider $p_1 \in \Lambda$ a hyperbolic fixed point for f_1 . Let $P_0 = (p_1, p_2)$.

Let ϕ^s be the linear contracting map given by $Df_2|_{E_{p_2}^s}$. Proposition 2.3 gives a number l as a required number of elements of IFS to obtain transitivity in some small disk. This number only depends on the dimension of N and the contraction bound of ϕ^s .

We fix the number $d = 2l + 4$, and its related k and U as above. And let $\mathcal{I} = \{1, 2, \dots, d - 4\}$, $\mathcal{J}_1 = \{1, d - 3, d - 2\}$ and $\mathcal{J}_2 = \{1, d - 1, d\}$.

Let $\delta > 0$ is small enough and $\varepsilon : [0, 1] \longrightarrow [0, \delta]^2$ is an smooth simple curve such that $\varepsilon(0) = (0, 0)$.

Let $F_0 = f_1 \times f_2$.

For $\mu \in (0, 1]$, F_μ is defined as the following. Let $(\varepsilon_1, \varepsilon_2) := \varepsilon(\mu)$, and consider Hamiltonians $\varepsilon_1 \tilde{h}_1$ and $\varepsilon_2 \tilde{h}_2$ supported on pairwise disjoint sets as follows. Let ψ_{ε_1} and ψ_{ε_2} , respectively their associated diffeomorphism. Now let $\Psi_\mu = \psi_{\varepsilon_2} \circ \psi_{\varepsilon_1}$. Since the support of ψ_{ε_i} 's are pairwise disjoint, they may commute with each others.

We define

$$F_\mu := \Psi_\mu \circ F_0.$$

The aim of this chapter is to show that F_μ has the properties claimed in Theorem A. One may describe briefly the perturbation Hamiltonians as the following:

1. Let Hamiltonian $\tilde{h}_1 : M \times N \longrightarrow \mathbb{R}$ supported on $(\tilde{\mathcal{A}}_{\mathcal{I}} \setminus \tilde{\mathcal{A}}_{1*}) \times N$, such that $\psi_{\varepsilon_1} \circ F_0$ has a symplectic blender. The detailed definition of \tilde{h}_1 is presented in Section 4.2 and there we show the existence of a blender (P_0, \mathcal{B}) .
2. The Hamiltonian $\tilde{h}_2 : M \times N \longrightarrow \mathbb{R}$ is supported on $(\tilde{\mathcal{A}}_{\mathcal{J}_1} \setminus \tilde{\mathcal{A}}_{1*}) \times N$ and its restriction to $\Lambda \times N$ is locally constant with respect to variables in M . More precisely,

$$\psi_{\varepsilon_2} \circ F_0(x, q) = (f_1(x), \phi_1 \circ f_2(q)), \quad \text{if } x \in \mathcal{A}_{d-3,*},$$

$$\psi_{\varepsilon_2} \circ F_0(x, q) = (f_1(x), \phi_2 \circ f_2(q)), \quad \text{if } x \in \mathcal{A}_{d-2,*},$$

where ϕ_1 and ϕ_2 are obtained in the proof of Theorem 2.12 (1). In Section 4.3 using the symbolic dynamics and the result of Section 2.2 we show that for almost every z in the fibers $\{x\} \times N$,

$$W^{ss(uu)}(z; F_\mu) \cap \mathcal{B} \neq \emptyset.$$

4.2 Constructing symplectic blender

Here we show that how to define the perturbation $\tilde{h}_1 : M \times N \longrightarrow \mathbb{R}$ in order to create a symplectic blender $\mathcal{B} = \mathcal{A}_{\mathcal{I}} \times B$. In fact, based on the affine models of Chapter 3, we also sketch the proof of Theorem 3.9. Notice that Theorem A satisfies the hypotheses of Theorem 3.9.

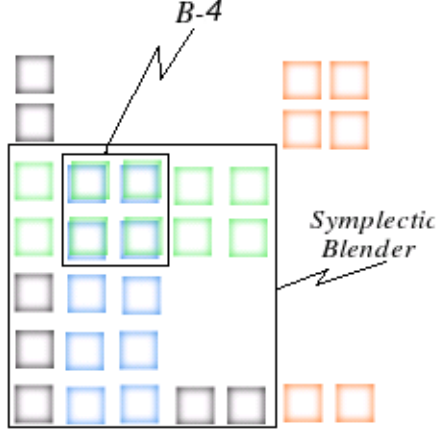

Figure 4.1: Support of local perturbations projected to Λ . The blocks with the same color are in the support of the same Hamiltonians. No perturbation is made in the black or white parts

Proof of Theorem 3.9.

Let $* = s, u$ and φ^* be the linear (contracting/expanding) map given by $Df_2|_{E_{p_2}^*}$. Proposition 2.3 gives the linear maps $\varphi_1^* := \varphi^*, \varphi_2^*, \dots, \varphi_l^*$ on $E_{p_2}^*$, such that $|\varphi_i^* - \varphi^*| < \epsilon_1$, and the corresponding IFS is transitive in some small disk D^* , satisfying the covering property. We let $B = D^s \times D^u$. By the Hartman-Grobman Theorem, one knows that f_2 in some open set $U_B \subset N$ is conjugate to the linear map $\varphi^s \times \varphi^u$ in B .

Now we define Hamiltonian \tilde{h}_1 in order to realize above IFS's. Recall that ψ_{ϵ_1} is the time one map of $\epsilon_1 \tilde{h}_1$.

For $i = 1, 2, \dots, l$, we let

$$\phi_i^s := \varphi_i^s, \quad \phi_i^u := \varphi^u.$$

And for $i = l + 1, l + 2, \dots, 2l$, we set

$$\phi_i^s := \varphi^s, \quad \phi_i^u := \varphi_{i-l}^u.$$

For simplicity we use the same notation for f_2 on U_B and its local linear maps $\phi^s \times \phi^u$ on B . Then, it follows that for $i, j \in \mathcal{I}$,

$$F_\mu(x, q) = \psi_{\varepsilon_1} \circ F_0(x, q) = (f_1(x), (\phi_i^s \times \phi_j^u)(q)), \quad \text{if } x \in \mathcal{A}_{i,j}, q \in B,$$

We identify f_1 to its restriction to Λ . For any $p = (p_i)_{i \in \mathbb{Z}} \in \Lambda = \{1, 2, \dots, d\}^{\mathbb{Z}}$, the local and global unstable manifolds of p for f_1 are

$$W_{loc}^u(p; f_1|_\Lambda) = \{(x_i) \mid \forall n \leq 0, x_i = p_i\}$$

$$W^u(p; f_1|_\Lambda) = \{(x_i) \mid \exists n_0 \in \mathbb{Z}, \forall n \leq n_0, x_i = p_i\}$$

From the fact that F_μ is a product in each $\mathcal{A}_{i,j} \times B$ then follows that $W_{loc}^u(p; f_1|_\Lambda) \times \{q\}$ is contained in the unstable manifold of (p, q) . Since this set is an embedded disk of the same dimension of the strong unstable subbundle associated to (p, q) follows that the local and global strong unstable manifolds of (p, q) for F_μ are

$$W_{loc}^{uu}(p, q; F_\mu|_\Gamma) = W_{loc}^u(p; f_1|_\Lambda) \times \{q\} = \{(x_i) \mid \forall n \leq 0, x_i = p_i\} \times \{q\},$$

$$W^{uu}(p, q; F_\mu|_\Gamma) = \bigcup_{n \geq 0} F_\mu^n(W_{loc}^{uu}(F_\mu^{-n}(p, q); F_\mu|_\Gamma)).$$

And also, similar to the affine models, a u -strip may be defined by

$$\Delta = \gamma^{uu} \times \mathcal{D}^u \times \{q^s\}.$$

where γ^{uu} is a local unstable leaf in $\mathcal{A}_{\mathcal{I}}$ for $f_1|_\Lambda$; \mathcal{D}^u is an open set in D^u , and $q^s \in D^s$.

Thus, there is some $i \in \mathcal{I}$ such that for any $j \in \mathcal{I}$, the u -strip Δ intersects $\mathcal{A}_{i,j} \times B$. Therefore,

$$F_\mu(\Delta) \supset \bigcup_{j \in \mathcal{I}} \gamma_{i(j)}^{uu} \times \phi_j^u(\mathcal{D}^u) \times \{q_{i(j)}^s\},$$

for some $\gamma_{i(j)}^{uu}$ local unstable leaves in $\mathcal{A}_{\mathcal{I}}$ for $f_1|_{\Lambda}$, and some $q_{i(j)}^s \in D^s$. Then, by induction we get,

$$F_{\mu}^k(\Delta) \supset \bigcup_{\Sigma \in \mathcal{I}^k} \gamma_{i(\Sigma)}^{uu} \times \phi_{\Sigma}^u(\mathcal{D}^u) \times \{q_{i(\Sigma)}^s\}.$$

We project this set along the strong unstable foliation and also along the stable foliation. Then the fixed point of ϕ_1^u corresponds to the local stable manifold of P_0 . The iterations of the fixed point of ϕ_1^u under the IFS of ϕ_j^u 's, also correspond to some parts of the global stable manifold of P_0 . The results of Section 2.1 shows that the IFS of ϕ_j^u 's is transitive. Indeed, the fixed point of ϕ_1^u has a dense orbit in D^u (under the IFS of ϕ_j^u 's). Therefore, the projection of $W^s(P_0)$ along the strong unstable foliation in \mathcal{B} is dense on D^u . This implies that $W^s(P_0)$ intersects any u -strip in \mathcal{B} .

Similarly we can show that $W^u(P_0)$ intersects any s -strip in \mathcal{B} . In other words, the pair (P_0, \mathcal{B}) is a symplectic blender for F_{μ} . \square

In addition, we have the following proposition which is a consequence of the first part of Proposition 2.5.

Proposition 4.1. *Let $\Lambda_B := \mathcal{A}_{\mathcal{I}} \cap \Lambda$. Under the hypotheses of Theorem 3.9 it is possible to create symplectic blender with the following additional property:*

B-4 *Any forward and backward iteration of a uu -leaf (ss -leaf) intersecting $\Lambda_B \times B$, intersects $\Lambda_B \times B$ in a uu -segment (ss -segment, respectively).*

Consequently, the set of all points whose strong (un)stable manifolds intersect $\Lambda_B \times B$, is an invariant set.

Note that we can not replace the set $\Lambda_B \times B$ by the open set \mathcal{B} .

4.3 Almost minimality of stable and unstable foliations

In this section that the strong stable and unstable manifolds of almost all points in the central manifold $N_0 := \{p_1\} \times N$ intersects the constructed blender. We refer to this property by the almost minimality of the strong stable and unstable foliations.

Proposition 4.2. *Let $\underline{p} \in \Lambda$ be a fixed point of f_1 which is not in the support of our perturbations. Then there is an open and dense set $\mathcal{R} \subset N$ with total Lebesgue measure such that for every $q \in \mathcal{R}$ and for any $n \in \mathbb{Z}$, $W^{uu}(F_\mu^n(\underline{p}, q)) \cap \mathcal{B} \neq \emptyset$.*

Proof. The key elements in the proof are the symbolic dynamics, the results of section 2.2 and Proposition 4.1.

We consider restriction of f_1 to Λ . For any $p = (p_i)_{i \in \mathbb{Z}} \in \Lambda = \{1, 2, \dots, d\}^{\mathbb{Z}}$, the local and global unstable manifolds of p for f are

$$W_{loc}^u(p; f|\Lambda) = \{(x_i) \mid \forall n \leq 0, x_i = p_i\}$$

$$W^u(p; f|\Lambda) = \{(x_i) \mid \exists n_0 \in \mathbb{Z}, \forall n \leq n_0, x_i = p_i\}$$

The above remark implies that the local and global strong unstable manifolds of (p, q) for F_μ are

$$W_{loc}^{uu}(p, q; F_\mu|\Gamma) = W_{loc}^u(p; f|\Lambda) \times \{q\} = \{(x_i) \mid \forall n \leq 0, x_i = p_i\} \times \{q\},$$

$$W^{uu}(p, q; F_\mu|\Gamma) = \bigcup_{n \geq 0} F_\mu^n(W_{loc}^{uu}(F_\mu^{-n}(p, q); F_\mu|\Gamma)).$$

Let $T_1 = f_2$, $T_2 = \phi_1 \circ f_2$ and $T_3 = \phi_2 \circ f_2$, where ϕ_1 and ϕ_2 are given as in the proof of Theorem 2.12 (1).

Let $q \in Rec(f_2) \subset N$ such that there is a finite sequence $(\sigma_i)_{i=1}^n$ such that $\sigma_i \in$

$\{1, 2, 3\}$ and

$$T_{\sigma_n} \circ T_{\sigma_{n-1}} \circ \cdots \circ T_{\sigma_1}(q) \in T_1^{-2}(B).$$

We denote the set of all such points by \mathcal{R}_1 .

Now, we consider

$$x = (x_i) = (\overbrace{\dots, p_{-2}, p_{-1}, p_0}^{W_{loc}^u(p)} ; \overbrace{a_1, a_2, \dots, a_{n_0}}^{IFS}, 1, 1, \overbrace{x_{n_0+3}, \dots}^{arbitrary}),$$

where for $i = 1, 2, \dots, n_0$,

$$a_i = 1 \quad \text{if } \sigma_i = 1,$$

$$a_i = d - 3 \quad \text{if } \sigma_i = 2,$$

$$a_i = d - 2 \quad \text{if } \sigma_i = 3.$$

It is clear that $x \in W^u(\underline{p}, f_1|\Lambda)$ and so $(x, q) \in W^{uu}(p, q; F_\mu|\Gamma)$. We now take the iterations of the point (x, q) under F_μ . Since F_μ restricted to $\mathcal{A}_{a_i, \mathcal{J}_1} \times N$ is equal to $f_1 \times T_{\sigma_i}$, inductively we have:

$$(f_1^i(x), T_{\sigma_i} \circ T_{\sigma_{i-1}} \circ \cdots \circ T_{\sigma_1}(q)) = F_\mu^i(x, q) \in W^{uu}(F_\mu^i(\underline{p}, q); F_\mu).$$

In particular, for $i = n_0 + 1$, $F_\mu^{n_0+1}(x, q) \in \mathcal{B}$. So,

$$W^{uu}(F_\mu^{n_0+1}(\underline{p}, q); F_\mu) \cap \mathcal{B} \neq \emptyset.$$

Now we apply Proposition 4.1. It implies that for all $n \in \mathbb{Z}$,

$$W^{uu}(F_\mu^n(\underline{p}, q); F_\mu) \cap \mathcal{B} \neq \emptyset.$$

Let \mathcal{R} the set all points $q \in N$ such that the above intersection holds. We proved that $\mathcal{R}_1 \subset \mathcal{R}$. The set \mathcal{R} is open, because \mathcal{B} is open and (the compact parts of)

the strong stable and unstable manifolds depends continuously to the points. On the other hand, in Section 2.2 it was shown that the set \mathcal{R}_1 has total Lebesgue measure. This completes the proof. \square

Remark 4.3. As a matter of fact, any skew product symplectic diffeomorphisms on a connected manifold is in fact a direct product of two symplectic diffeomorphism. Let us explain it for the Hamiltonians. Let $U \subset \mathbb{R}^{2n} \times \mathbb{R}^{2m}$, and $h : U \times \mathbb{R} \rightarrow \mathbb{R}$ be a Hamiltonian function and f be the time-one map of its corresponding flow. If $f(x, y; p, q) = (x, y, g(x, y; p, q))$, where x_i and y_i are symplectic conjugate variables and the same for p_i and q_i , then

$$\dot{x}_i = -\frac{\partial h}{\partial y_i} = 0, \quad \dot{y}_i = \frac{\partial h}{\partial x_i} = 0, \quad \dot{p}_i = -\frac{\partial h}{\partial q_i}, \quad \dot{q}_i = \frac{\partial h}{\partial p_i}.$$

The first two equalities implies that h does not depend to x and y . So f is the product $id \times g$.

This is no longer true for disconnected invariant sets. So, we see that F_μ is a skew-product on the disconnected invariant set $\Lambda \times N$, while it could not be a skew product on $M \times N$.

4.4 Robustness of the almost minimality of foliations

The hypothesis (b) in Theorem A implies that F_0 is partially hyperbolic on $\Gamma_{F_0} := \Lambda \times N$ which is locally maximal. More precisely by the results of [HPS] we have:

H-1 Γ_{F_0} is normally hyperbolic and F is plaque expansive (see [HPS, p.116 and Theorem 7.2]).

H-2 There is a neighborhood $\mathcal{U} \subset \text{Diff}^1(M \times N)$ of F such that every $G \in \mathcal{U}$ has a

(locally maximal) invariant Γ_G homeomorphic to $\Lambda \times N$ and is a continuation of Γ_{F_0} .

H-3 There is a G -invariant foliation on Γ_G by manifolds diffeomorphic to N that is, the continuation of fibration defined on $\Lambda \times N$. So G induces a homeomorphism \tilde{G} on the quotient of Γ_G by the foliation. It then follows that \tilde{G} is conjugate to $f_1|_\Lambda$ (see [HPS, Theorem 7.1]).

H-4 G restricted to Γ_G is conjugate to a skew product $G^* : (x, w) \mapsto (f_1(x), g_x(w))$ on $\Lambda \times N$, which depends continuously on G .

Given $N_c \subset\subset N$, let $\Gamma_{G, N_c} \subset \Gamma_G$ the continuation of $\Lambda \times N_c$, that is, the image of $\Lambda \times N_c$ by the homeomorphism given in **H-2** above. We let $N_0 := \{p_1\} \times N$, and \tilde{N}_0 is the continuation of N_0 for G .

In order to have all the above properties it is enough to consider the family $\{F_\mu\}$ in the set \mathcal{U} , by taking $\delta > 0$ small enough.

If $W^{uu}(p, q; F_\mu) \cap \mathcal{B} \neq \emptyset$, then there is $L > 0$ large enough, such that $W^{uu}(p, q; F_\mu) \cap \mathcal{B}$ contains a uu -segment of \mathcal{B} . \mathcal{B} is open, so there is a neighborhood $V_{(p,q)}$ of (p, q) such that for any point $z \in V_{(p,q)}$, $W^{uu}(z; F_\mu) \cap \mathcal{B}$ contains a uu -segment of \mathcal{B} .

In Section 4.3 we proved that the set \mathcal{R} of points whose strong stable and unstable manifolds intersects \mathcal{B} is dense (and of total measure) in N_0 . Now we see that \mathcal{R} contains an open dense subset of N_0 .

We call $X = N \setminus \mathcal{R}$ the *exceptional set*, which is a closed set with empty interior and of zero measure.

Then, given *any* compact set $R_c \subset \mathcal{R}$, there is some large L such that for any $z \in R_c$, $W_{L_c}^{uu}(z; F_\mu) \cap \mathcal{B}$ contains a uu -segment of \mathcal{B} .

Since the compact parts of (strong) stable and unstable manifolds depends continuously to the diffeomorphism, there exists \mathcal{W}_{μ, R_c} , a neighborhood of F_μ , such that

for any $G \in \mathcal{W}_{\mu, R_c}$, and any $z \in \Gamma_{G, R_c}$, $W_{L_c}^{uu}(z; G) \cap \mathcal{B}$ contains a uu -segment of \mathcal{B} (w.r.t. G).

In other words, we have robustness of the almost minimality of strong stable and unstable foliations. \square

4.5 Transitivity and topological mixing

Recall the following two general fact on symplectic diffeomorphisms.

S-1 A normally hyperbolic invariant submanifold of symplectic diffeomorphism is a symplectic submanifold (with a canonical 2-form which is the restriction of the given symplectic form) and

S-2 The restriction of a symplectic diffeomorphism to its normally hyperbolic invariant submanifolds is preserving the restricted symplectic form.

Therefore, using **H-1 - H-4**, **S-1** and **S-2**, the hypothesis (b) in Theorem A, yield that if the neighborhood \mathcal{U} of F_0 is small enough, then for any $G \in \mathcal{U}$, $G|_{\tilde{N}_0}$ is (smoothly) conjugate to a diffeomorphism g which is C^r close to f_2 in $\text{Diff}_\omega^r(N)$ and so all points in \tilde{N}_0 are non-wandering for G . As mentioned before, the family F_μ is constructed in \mathcal{U} .

Let N_c be any open and bounded domain in N . Given $\nu > 0$, let $X_{c,\nu} = \overline{B_\nu}(N_c \cap X)$. And let $R_{c,\nu} = N_c \setminus X_{c,\nu} \subset R$.

Now for any $G \in \mathcal{W}_{\mu, R_{c,\nu}}$, we first show that,

$$\tilde{R}_{c,\nu} \subset \overline{W^s(P_G)} \cap \overline{W^u(P_G)},$$

recall that, P_G is the continuation of the hyperbolic point (p_1, p_2) .

Let Δ be an open set in Γ_G such that $\Delta \cap \tilde{R}_{c,\nu} \neq \emptyset$. Then, for any large number n_0 , there is a point $z^* \in \Delta$ such that $G^n(z^*) \in \Delta \cap \tilde{R}_{c,\nu}$ for some $n \geq n_0$.

Let $\gamma = W^{uu}(z^*; G) \cap \Delta$, then for some large $n > 0$, $G^n(\gamma)$ has diameter larger than L_c and so contains $W_{L_c}^{uu}(G^n(z^*); G)$. Since $G^n(z^*) \in R_{c,\nu}$, we conclude that $G^n(\gamma)$ contains a uu -segment in \mathcal{B} . Thus $G^n(\Delta)$ contains a u -strip in \mathcal{B} . The property **B-4** of *double-blender* implies that $W^s(P_G; G)$ intersects $G^n(\Delta)$ and so

$$W^s(P_G; G) \cap \Delta \cap \Gamma_G \neq \emptyset.$$

For any open set Δ' in Γ_G such that $\Delta' \cap \tilde{R}_{c,\nu} \neq \emptyset$, similarly we can show that some iteration of Δ' contains a s -strip in the blender \mathcal{B} , and so $W^u(z_G; G)$ intersects Δ' in Γ_G .

In other words, the closure of stable and unstable manifolds of P_G for G are both contain $\tilde{R}_{c,\nu}$, for any \tilde{N}_c and ν .

Now, **H-4** and the density of f_1 - stable and unstable manifold of p_1 in Λ implies that,

$$\Gamma_{G,R_{c,\nu}} \subset \overline{W^s(P_G; G)} \cap \overline{W^u(P_G; G)}.$$

In particular for any F_μ ,

$$\Gamma_{F_0} \subset \overline{W^s(P_0; F_\mu)} \cap \overline{W^u(P_0; F_\mu)}.$$

Whenever the stable and unstable manifolds of a periodic hyperbolic point are both dense on some set, the inclination Lemma provides transitivity and topological mixing.

Thus, for any N_c and $\nu > 0$,

- i) $R_{c,\nu}$ is topological mixing for G .
- ii) $\Gamma_{G,R_{c,\nu}}$ is strictly topological mixing for G .

And in particular,

- i) N_0 is topological mixing for any F_μ
- ii) $\Gamma_{F_0} = \Lambda \times N$ is strictly topological mixing for any F_μ .

The proof of Theorem A is completed. □

Remark 4.4. In the perturbations introduced in the proofs we could use the generating functions instead the Hamiltonians. It lets us to unify the proof of Theorem A and its variation for the Hamiltonians. The Hamiltonian version of Theorem A shall be used in the proof of Theorem C.

Chapter 5

Instabilities in nearly integrable systems

5.1 Instability versus recurrency

The following basic lemma shall be used in the proof of Theorem C.

Lemma 5.1. *There is a residual subset \mathcal{R} of $\text{int}(\Omega(f))$ such that any point in \mathcal{R} is a (positively and negatively) recurrent point.*

Proof. Let $\mathfrak{B} = \{U_i : i \in \mathbb{N}\}$ be a countable topological base in $\text{int}(\Omega(f))$. For every $i \in \mathbb{N}$, there is $n_i \in \mathbb{N}$ such that $f^{n_i}(U_i) \cap U_i = \emptyset$. Let $x_i \in V_i := f^{-n_i}(U_i) \cap U_i$. Since $\mathfrak{B}_k = \{U_i : i \geq k\}$ is also a topological base, the set $\{x_i\}_{i=k}^{\infty}$ is dense in $\text{int}(\Omega(f))$. So $\bigcup_{i=k}^{\infty} V_i$ is open and dense subset of $\text{int}(\Omega(f))$. Then, $\mathcal{R}^+ := \bigcap_{k=1}^{\infty} \bigcup_{i=k}^{\infty} V_i$ is residual. We claim that $\mathcal{R}^+ \subset \text{Rec}^+(f)$. Since \mathfrak{B} is a topological base, for any $\epsilon > 0$ there is a k_ϵ such that, if $i > k$ then $\text{diam}(U_i) < \epsilon$. Now, for any $x \in \mathcal{R}^+$ and for $i > k_\epsilon$, $x \in V_i$. So there is $n_i \in \mathbb{N}$ such that, $d(f^{n_i}(x), x) < \text{diam}(U_i) < \epsilon$. Since $\epsilon > 0$ was arbitrary, this implies that x is a positively recurrent point. We could do it for f^{-1} to obtain a residual subset \mathcal{R}^- of negatively recurrent points. Any point in the residual set $\mathcal{R} = \mathcal{R}^- \cap \mathcal{R}^+$ is positively and negatively recurrent. \square

We say that a point x converges to infinity if for any bounded set U there is a number n_0 such that for any $n > n_0$, $f_n(x) \notin U$.

The following lemma is a corollary of a variation of Poincaré recurrence Theorem for unbounded measures (due to Hopf) which yields that for conservative homeomorphisms on the manifolds with unbounded measure, almost all points either are recurrent or converge to infinity.

Lemma 5.2. *Let f be a conservative homeomorphism on a non-compact manifold with unbounded Lebesgue measure. Then Lebesgue almost all points in $\Omega(f)^{\mathbb{G}}$ converge to infinity, in the future and also past iterations.*

As a matter of fact, similar results may be stated on each fiber of the invariant sets such as Γ_G in Theorem A. That is, “almost all points” means “almost all points with respect to the Lebesgue measure on each fiber”, also residual and open sets in the restricted topology in fibers.

Now, suppose that the assumption (b) in Theorem A fails. For instance, suppose that $\Omega(f_2) = N$ but for some \tilde{f} close to f_2 , $\Omega(\tilde{f}_2) \subsetneq N$. In this case, the same results on transitivity and topologically mixing hold on the interior of non-wandering set. Indeed, we used the hypothesis $\Omega(\tilde{f}_2) = N$, only in the last step of the proof to show that some of the arbitrary large iterations of generic points in \tilde{N}_c remain in some desired compact set $\tilde{N}_{c'}$. This follows from Lemma 5.1.

In contrast, let $U_c \subset\subset M \times N$ be an open set and $\Gamma_{G,c} = U_c \cap \Gamma_G$ such that $\Gamma_{G,c} \not\subseteq \Omega(G)$. Then, almost all points in some open subset of U_c converge to infinity in the past and in the future. Moreover, there is an open set $V_c \subset U_c$ such that

1. $V_c \cap \Gamma_{G,c} \neq \emptyset$.
2. Almost all (w.r.t the restricted Lebesgue measure) points in $V_c \cap N_c^x$ goes to infinity both in the past and the future, where N_c^x is the intersection of some fiber N^x with U_c . In this case, we have a sense of instability, that is, orbits which

come from infinity and stay for some iterations near a transitive invariant set and then go back to infinity.

These facts together with Theorem A leads to a dichotomy in this context:

existence of large robustly transitive sets or
existence of wandering orbits converging to infinity.

5.2 Proofs of Theorem C and Corollary D

In this section we complete the proofs of Theorem C and Corollary D. First we recall the following result of Zenhder [Z] and Newhouse [Ne].

Theorem 5.3 (Zenhder-Newhouse). *There is a residual set $\mathbf{R} \subset \text{Diff}_\omega^r(M)$, $1 \leq r \leq \infty$, such that if $f \in \mathbf{R}$, then any quasi-elliptic periodic point of f is a limit of transversal homoclinic points of f .*

A periodic point p of f of period n is called *quasi-elliptic* if $T_p f^n$ has a non-real eigenvalue of norm one, and all eigenvalues of norm one are non-real. Notice that if f is Anosov, then robustly there is no quasi-elliptic periodic point. Indeed, C^r generically every periodic point is either hyperbolic or quasi-elliptic (cf. [Ne]).

Proof of Theorem C. Let f_1 and f_2 be the time one map of the flow generated by the Hamiltonians h_1 and h_2 respectively. Since f_2 is integrable, it is dominated by $f_1|_\Lambda$, and moreover a generic small perturbation of f_2 has some hyperbolic periodic point with arbitrary weak hyperbolicity. Let \hat{f}_2 be a small perturbation of f_2 such that its non-wandering set is the whole manifold N and has a hyperbolic periodic point (with weak hyperbolicity). If \hat{f}_2 is enough close to f_2 then it is also dominated by $f_1|_\Lambda$. Now we may repeat the prove of Theorem A for $F_0 = f_1 \times \hat{f}_2$. Note that all the perturbations had been done by some Hamiltonians. Then we obtain a family of Hamiltonians H_μ for each of which the time one map F_μ of the corresponding flow

satisfies the properties (1) and (2) in Theorem A. Fix $N_c \subset\subset N$ and $\nu > 0$. As in Theorem A, there exists a neighborhood $\mathcal{W}_{c,\nu}$ of the constructed family $\{H_\mu : \mu > 0\}$ such that if $H \in \mathcal{W}_{c,\nu}$ and G is its corresponding time one map, then one of the following possibilities hold, either $\tilde{R}_c \subset \Omega(G)$ or not. Here $R_{c,\nu}$ is a compact set no exceptional point (see the definition in Section 4.5) and $\tilde{R}_{c,\nu}$ is its continuation w.r.t. G . If $\tilde{R}_c \subset \Omega(G)$ then we may follow the final part of the proof of Theorem A to show that $\tilde{R}_{c,\nu}$ is topologically mixing. Otherwise, if $\tilde{R}_c \not\subset \Omega(G)$ then we use the results of Section 5.1. In this case, for a residual subset of $\tilde{R}_c \cap \Omega(f)^{\mathbb{G}}$ all points converge to infinity, both in past and in the future. This completes the proof. \square

Proof of Corollary D. Let $M = \mathbb{R}^n \times \mathbb{T}^n$ and $N = \mathbb{R} \times \mathbb{T}^1$. First we perturb the hamiltonian h_1 on M to obtain a transversal homoclinic intersection. Since h_1 has a non hyperbolic periodic point, by a small perturbation we make it quasi-elliptic. Theorem 5.3 yields that for any C^r generic perturbation \tilde{h}_1 of h_1 , this orbit is accumulated by hyperbolic periodic points with homoclinic transversal intersections. Note that h_2 is dominated by the restriction of \tilde{h}_1 on the hyperbolic basic set obtained from the homoclinic transversal intersection.

Now, we take another small (generic) perturbation \tilde{h}_2 of the integrable Hamiltonian h_2 on N to create a weak hyperbolic periodic point.

Since $r \geq 5$, N is of dimension two and the integrable hamiltonian h_2 is non-degenerate, then KAM Theorem implies that the non-wandering set *robustly* contains the manifold N . In other word, the time one map f_2 of the flow generated by h_2 satisfies the hypothesis (b) of Theorem A. In particular all the hypotheses of Theorems A and C hold for \tilde{h}_1 and \tilde{h}_2 (and their associated time on maps). Now we use Theorems A and C, and it completes the proof. \square

Remark 5.4. If the dimension of N is two, then either any point in N_0 belongs to some compact invariant region limited by two invariant curves or there is an unbounded Birkhoff region of instability. In the former case we obtain transitivity since the

hypothesis (b) of Theorem A holds. In the latter case the instability region contains orbits starting near to one boundary and converge to infinity (this is a classical result of Birkhoff). As in the Corollary C, if the integrable system on N is non-degenerate and $r \geq 5$, then using KAM Theorem the hypothesis (b) holds and the second case does not occur. In the lower regularity or in the degenerate case the hypothesis (b) does not hold in general. In this case the union of the images of the non-wandering set in N_0 under all the su -holonomy maps, contains the boundary of the Birkhoff instability region. It implies that the orbit of any open set intersecting the non-wandering set in N_0 , is unbounded and its closure contains the non-wandering set in N_0 .

Chapter 6

Some remarks and open problems

The main results of this paper arise several natural questions. Here we mention some of them. The first remark is concerned with a possible alternative approach to prove transitivity.

Remark 6.1. In the context of Theorem A, the accessibility with the density of recurrent point implies transitivity (but not mixing). Without the global hyperbolicity it is difficult to obtain “stable” accessibility. First, it seems essential to suppose that the Hausdorff dimension of the hyperbolic set Λ to be large enough. Second, for stability of accessibility one needs the continuity of Hausdorff dimension of the projections of the (hyperbolic) Cantor set along the invariant foliations. Unfortunately, the stable and unstable foliations are not smooth, and so the Hausdorff dimension of the projections do not vary continuously. A similar difficulty occurs in the persistence of homoclinic tangencies in higher dimensions.

1. Transitivity and partial hyperbolicity

The first question concerns the genericity of the robustly mixing partially hyperbolic sets. Theorem A suggests that the answer of the following problem would be positive. See also [N].

Problem 6.2. *Does there exist a residual set $\mathbf{R} \subset \text{Diff}_\omega^r(M)$, $1 \leq r \leq \infty$, such that if $f \in \mathbf{R}$, then any normally hyperbolic invariant submanifold N for f with transversal intersection between its stable and unstable manifolds is topologically mixing, provided that $N \subset \text{int}(\Omega(f))$?*

In contrast, as in the case of C^1 topology (see [DPU], [BDP] and [HT]), we believe that the partial hyperbolicity condition is *necessary* for robustness of mixing in any C^r topology. This problem is also related to the C^r stability conjecture which is still open.

Problem 6.3. *Let (M, ω) be a symplectic manifold. Suppose that Γ is robustly topological mixing invariant set for f in $\text{Diff}_\omega^r(M)$. Is it a partially hyperbolic set?*

2. Ergodicity and stable ergodicity

Let f_1 and f_2 as in Theorem A. Suppose that N is compact. Then the topologically mixing invariant set obtained in Theorem A is laminated by central manifolds diffeomorphic to N . This lamination is normally hyperbolic. See **H-1–H-4**, **S-1** and **S-2**, in Section 4.4. As a matter of fact, this implies that for all symplectic diffeomorphism G near to $f_1 \times f_2$, there is an invariant measure ρ_G supported the continuation of $\Lambda \times N$. Moreover, the measure ρ_G is a skew product of the Lebesgue measure on the fibers (i.e. the volume form obtained by the restriction the symplectic 2-form on the fibers) over the Bernoulli measure of the shift on $\Lambda = \{1, \dots, d\}^{\mathbb{Z}}$.

As was mentioned in the introduction, Theorem A can be seen as a local and topological version of the example Shub and Wilkinson [SW], where they proved that the product of “Anosov \times Standard map” on \mathbb{T}^4 is C^∞ approximation by (symplectic) stably ergodic systems. A natural problem arises:

Problem 6.4. *Is it possible to C^∞ approximate the product $f_1 \times f_2$ of Theorem A by symplectic diffeomorphisms G for which the invariant ρ_G supported the continuation of $\Lambda \times N$ is ergodic or stably ergodic? Is the compactness assumption on N necessary?*

3. Other contexts.

The other problems concern natural extensions and applications of our results and method in similar contexts. For instance,

1. analytic symplectic and Hamiltonian systems,
2. geodesic flows on manifolds of dimensions larger than two,
3. perturbations of geodesic flows on surfaces by periodic potentials,
4. the dynamics near the (quasi) elliptic periodic points in dimensions ≥ 4 ,
5. generic energy levels of time independent Hamiltonian systems,
6. specific mechanical problems such as restricted 3-body problem.

4. On the abundance of instability

Let the Hamiltonian H_0 be written as the sum of two functions which depend on different variables. In this paper we have proved that, if H_0 is integrable or has a partially hyperbolic invariant set, then $H_0 + h$ exhibits instability (Arnold diffusion) and large topological mixing set, where $h = \tilde{h}_0 + \epsilon_1 \tilde{h}_1 + \epsilon_2 \tilde{h}_2$, the C^r -norm of \tilde{h}_i 's are one, and h_0 is generic (open dense), h_1 is not generic, but h_2 is *arbitrary*. Moreover, $0 < \epsilon_i < \epsilon_i(h_1, h_0)$.

Bibliography

- [ABC] M.-C. Arnaud, C. Bonatti, S. Crovisier, Dynamiques symplectiques génériques. *Ergodic Theory Dynam. Systems* **25** (2005), no. 5, 1401–1436.
- [A1] V. I. Arnol'd, Small denominators and problems of stability of motion in classical and celestial mechanics, *Uspehi Mat. Nauk* **18** (1963), no. 6 (114), 91–192
- [A2] V. I. Arnol'd, Instability of dynamical systems with several degrees of freedom, *Dokl. Akad. Nauk SSSR* **156** (1964), 9–12.
- [BC] C. Bonatti, S. Crovisier, Récurrence et genericité. *Invent. Math.* **158** (2004), no. 1, 33–104.
- [BD] C. Bonatti, L. J. Díaz, Persistence nonhyperbolic transitive diffeomorphisms, *Annals of Math. (2)*, **143**:357–396, 1996.
- [BDP] C. Bonatti, L. J. Díaz, E. Pujals, A C^1 -generic dichotomy for diffeomorphisms: Weak forms of hyperbolicity or infinitely many sinks or sources, *Annals of Math. (2)*, **158** (2003), no. 2, 355–418.
- [BDV] C. Bonatti, L. J. Díaz, M. Viana, *Dynamics beyond uniform hyperbolicity*, Encyclopedia of Mathematical Sciences, Springer Verlag, 2004.
- [CY] C. -Q. Cheng, J. Yan, Existence of Diffusion Orbits in a priori Unstable Hamiltonian Systems, *J. Diff. Geom.* **67** (2004) 457-517.

- [DLS] A. Delshams, R. de la Llave, T.M. Seara, A geometric mechanism for diffusion in Hamiltonian systems overcoming the large gap problem: heuristics and rigorous verification on a model, *Mem. Amer. Math. Soc.* **179** (2006), no. 844, viii+141 pp.
- [DPU] L. J. Díaz, E. R. Pujals, R. Ures, Partial hyperbolicity and robust transitivity, *Acta Math.* 183 (1999), no. 1, 1–43.
- [D] R. Duady, Stabilité ou instabilité des points fixes elliptiques, *Ann. Sci. École Norm. Sup. (4)*, **21** (1988) no. 1, 1–46.
- [HPS] M. Hirsch, C. Pugh, M. Shub, *Invariant manifolds*, Lecture Notes in Math. 583, Springer, Berlin, 1977.
- [HT] V. Horita, A. Tahzibi, Partial hyperbolicity for Symplectic Diffeomorphisms, Preprint IMPA (2004), *Ann. Inst. H. Poincaré*, to appear.
- [KMV] V. Kaloshin, J. Mather, E. Valdinoci, Instability of resonant totally elliptic points of symplectic maps in dimension 4, *Asterisque*, No. 297 (2004), 79–116.
- [Mñ] R. Mañé, Contributions to the C^1 -stability conjecture, *Topology* **17** (1978), 386–396.
- [Ma] J. Mather, Arnold Diffusion. I: Announcement of Results, *Journal of Mathematical Sciences* **124** (5) : 5275–5289, December 2004.
- [N] M. Nassiri, Instability and transitivity in Hamiltonian systems, *In preparation*.
- [Ne] S. Newhouse, Quasi-elliptic periodic points in conservative dynamical systems, *Amer. J. Math.* **99** (1977), no. 5, 1061–1087.
- [PSh] C. Pugh, M. Shub, Stable ergodicity. With an appendix by Alexander Starkov, *Bull. Amer. Math. Soc. (N.S.)* **41** (2004), no. 1, 1–41.

- [PS] E. R. Pujals, M. Sambarino, Homoclinic bifurcations, dominated splitting, and robust transitivity, *Handbook of dynamical systems. Vol. 1B*, 327–378, Elsevier B. V., Amsterdam, 2006.
- [Sa] R. Saghin Generic Properties of Lagrangian Systems and Conservative Diffeomorphisms, Ph.D. thesis, Northwestern University, 2005.
- [Sh] M. Shub, Topological Transitive Diffeomorphism on \mathbb{T}^4 , *Lecture Notes in Math.* **206**, Springer-Verlag, New York, 1971.
- [SW] M. Shub, A. Wilkinson, Stably ergodic approximation: two examples, *Ergodic Theory Dynam. Systems* **20** (2000), no. 3, 875–893.
- [X] Z. J. Xia, Arnold diffusion: a variational construction, Proceedings of the International Congress of Mathematicians, Vol. II (Berlin, 1998). *Doc. Math.* **1998**, Extra Vol. II, 867–877.
- [Z] E. Zehnder, Homoclinic points near elliptic fixed points, *Comm. Pure Appl. Math.* **26** (1973), 131–182.